

IEEE Recommended Practice for Routine Impulse Test for Distribution Transformers

Sponsor

**Transformers Committee
of the
IEEE Power Engineering Society**

Approved 9 March 1998

IEEE-SA Standards Board

Abstract: General test procedures for performing routine quality control test that is suitable for high-volume, production line testing. Transformer connections, test methods, circuit configurations, and failure detection methods are addressed. This recommended practice covers liquid-immersed, single- and three-phase distribution transformers.

Keywords: distribution transformers, routine impulse test, production line testing

The Institute of Electrical and Electronics Engineers, Inc.
345 East 47th Street, New York, NY 10017-2394, USA

Copyright © 1998 by the Institute of Electrical and Electronics Engineers, Inc.
All rights reserved. Published 1998. Printed in the United States of America.

ISBN 0-7381-0176-1

No part of this publication may be reproduced in any form, in an electronic retrieval system or otherwise, without the prior written permission of the publisher.

IEEE Standards documents are developed within the IEEE Societies and the Standards Coordinating Committees of the IEEE Standards Association (IEEE-SA) Standards Board. Members of the committees serve voluntarily and without compensation. They are not necessarily members of the Institute. The standards developed within IEEE represent a consensus of the broad expertise on the subject within the Institute as well as those activities outside of IEEE that have expressed an interest in participating in the development of the standard.

Use of an IEEE Standard is wholly voluntary. The existence of an IEEE Standard does not imply that there are no other ways to produce, test, measure, purchase, market, or provide other goods and services related to the scope of the IEEE Standard. Furthermore, the viewpoint expressed at the time a standard is approved and issued is subject to change brought about through developments in the state of the art and comments received from users of the standard. Every IEEE Standard is subjected to review at least every five years for revision or reaffirmation. When a document is more than five years old and has not been reaffirmed, it is reasonable to conclude that its contents, although still of some value, do not wholly reflect the present state of the art. Users are cautioned to check to determine that they have the latest edition of any IEEE Standard.

Comments for revision of IEEE Standards are welcome from any interested party, regardless of membership affiliation with IEEE. Suggestions for changes in documents should be in the form of a proposed change of text, together with appropriate supporting comments.

Interpretations: Occasionally questions may arise regarding the meaning of portions of standards as they relate to specific applications. When the need for interpretations is brought to the attention of IEEE, the Institute will initiate action to prepare appropriate responses. Since IEEE Standards represent a consensus of all concerned interests, it is important to ensure that any interpretation has also received the concurrence of a balance of interests. For this reason, IEEE and the members of its societies and Standards Coordinating Committees are not able to provide an instant response to interpretation requests except in those cases where the matter has previously received formal consideration.

Comments on standards and requests for interpretations should be addressed to:

Secretary, IEEE-SA Standards Board
445 Hoes Lane
P.O. Box 1331
Piscataway, NJ 08855-1331
USA

Note: Attention is called to the possibility that implementation of this standard may require use of subject matter covered by patent rights. By publication of this standard, no position is taken with respect to the existence or validity of any patent rights in connection therewith. The IEEE shall not be responsible for identifying patents for which a license may be required by an IEEE standard or for conducting inquiries into the legal validity or scope of those patents that are brought to its attention.

Authorization to photocopy portions of any individual standard for internal or personal use is granted by the Institute of Electrical and Electronics Engineers, Inc., provided that the appropriate fee is paid to Copyright Clearance Center. To arrange for payment of licensing fee, please contact Copyright Clearance Center, Customer Service, 222 Rosewood Drive, Danvers, MA 01923 USA; (978) 750-8400. Permission to photocopy portions of any individual standard for educational classroom use can also be obtained through the Copyright Clearance Center.

Introduction

(This introduction is not part of IEEE Std C57.138, IEEE Recommended Practice for Routine Impulse Test for Distribution Transformers.)

William P. Lidinsky, Chair*
Tony Jeffree, Chair, Network Management Task Group*

The following persons were on the balloting committee:

Edward J. Adolphson	Lawrence A. Kirchner	Thomas Pekarek
Geroge Allen	Brian F. Klaponski	Mark D. Perkins
Jim Antweiler	Gary Klein	Linden Pierce
James C. Arnold Jr.	Alexander D. Kline	R. Leon Plaster
Donald E. Ballard	Egon Koenig	Bertrand Poulin
David A. Barnard	Alvin Kopp	Tom A. Prevost
William H. Bartley	Barin Kumar	Chris A. Robbins
W. J. "Bill" Bergman	John P. Lazar	John R. Rossetti
Wallace B. Binder	Singson Lee	Gerry W. Rowe
Alain Bollinger	Mark Loveless	Hazairin Samaulah
John D. Borst	Larry A. Lowdermilk	Mahesh P. Sampat
Charles V. Brown	Donald L. Lowe	Vallamkonda S. N. Sankar
David S. Brucker	Thomas Lundquist	Subhas Sarkar
Max A. Cambre	William A. Maguire	Rick Sawyer
Alvaro Cancino	Charles Mandeville	Vic Shenoy
Jerry L. Corkran	Richard P. Marek	Stephen Shull
Robert Degeneff	John W. Matthews	Hyeong Jin Sim
Alfonso M. Delgado	W. E. "Bill" McCain	Tarkeshwar Singh
Randall L. Dotson	L. Bruce McClung	Stephen D. Smith
Bruce Forsyth	Ben McConnell	James E. Smith
Dudley L. Galloway	Charles J. McMillen	Jerry W. Smith
Saurabh Ghosh	Nigel P. McQuin	Steven L. Snyder
Donald A. Gillies	C. Patrick McShane	Ronald J. Stahara
Ramsis S. Girgis	Sam P. Mehta	Ron W. Stoner
Richard D. Graham	Joe Melanson	John C. Sullivan
Robert L. Grunert	Sam Michael	Malcolm V. Thaden
Michael E. Haas	Daleep C. Mohla	James A. Thompson
Kenneth S. Hanus	W. E. "Gene" Morehart	Al Traut
Jack W. Harley	Daniel H. Mulkey	Subash C. Tuli
Tommy W. Hayes	Chuck R. Murray	Joseph J. Vaschak
George E. Henry III	R. J. Musil	Robert A. Veitch
Philip J. Hopkinson	Carl G. Niemann	Loren B. Wagenaar
John Hunt	Larry Nunnery	Ralph D. Wakeam
Charles W. Johnson	Paul Orehek	Barry H. Ward
Anthony J. Jonnatti	Gerald A. Paiva	D. W. Whitley
Joseph J. Kelly	Dhiru S. Patel	Alan L. Wilks
Sheldon P. Kennedy	Wesley F. Patterson	William G. Wimmer
Vladimir Khalin	Paulette A. Payne	David Woodcock
	Carlos Peixoto	

*Member Emeritus

When the IEEE-SA Standards Board approved this standard on 19 March 1998, it had the following membership:

John R. Rosetti, *Chair*

James C. Arnold Jr.
Donald E. Ballard
Charles V. Brown
Jerry L. Corkran
John C. Crouse
Reto H. Fausch
George E. Henry III
Larry L. Hilsenbeck

Richard A. Hollingsworth
Philip J. Hopkinson
Brian F. Klaponski
George K. Krause
Larry A. Lowdermilk
Arthur Molden
Harold R. Moore

Charles J. McMillen
Gerald A. Paiva
Francois Ruelland
James E. Smith
Stephen D. Smith
Michael A. Thornton
Ralph D. Wakeam
Alan L. Wilks

Noelle D. Humenick
IEEE Standards Project Editor

Contents

1. Overview.....	1
1.1 Scope.....	1
1.2 Purpose.....	1
2. References.....	1
3. General test procedures.....	2
4. Fault detection methods	2
5. Circuits for routine impulse testing.....	3
5.1 Impulse wave shape	3
5.2 Transformer connections	4
5.3 Grounding considerations	15
6. Neutral current detection circuit	15
6.1 Ground current circuit.....	15
6.2 Neutral-impedance circuit.....	16
6.3 CT circuit	17
7. Failure detection methods	18
7.1 Detection requirements	18
7.2 Comparison of wave shapes.....	19
7.3 Automatic failure detection.....	19
7.4 Special considerations.....	29
8. Verification of detector sensitivity.....	29
Annex A (informative) Distribution transformer voltage distribution and impulse fault detection	32

IEEE Recommended Practice for Routine Impulse Test for Distribution Transformers

1. Overview

1.1 Scope

This recommended practice covers routine impulse tests performed on distribution transformers, as required in IEEE Std C57.12.00-1993, and described in subclause 10.4 of IEEE Std C57.12.90-1993.

Distribution transformers covered by this recommended practice are liquid-immersed, single- and three-phase overhead-type up to 500 kVA; single-phase pad-mounted compartmental-type and underground-type up to 167 kVA; three-phase pad-mounted compartmental-type and underground-type up to 2500 kVA. These transformers are covered by IEEE Std C57.12.20-1988 through IEEE Std C57.12.26-1992.

This recommended practice covers only those aspects of impulse testing that are specific to routine testing of distribution transformers. For more thorough coverage of impulse testing of transformers in general, the IEEE Guide for Transformer Impulse Tests, IEEE Std C57.98-1993, should be consulted.

1.2 Purpose

This recommended practice is to assist manufacturers of distribution transformers in the setup and operation of a routine impulse test, and to assist distribution transformer users and purchasers in understanding the routine impulse test and how it differs from design tests.

2. References

When the following ANSI/IEEE standards and guides referred to in this recommended practice are superseded by a general revision approved by the American National Standards Institute, the latest revision shall apply.

This recommended practice shall be used in conjunction with the following publications:

IEEE Std 4-1995, IEEE Standard Techniques for High-Voltage Testing.¹

¹IEEE publications are available from the Institute of Electrical and Electronics Engineers, 445 Hoes Lane, P.O. Box 1331, Piscataway, NJ 08855-1331, USA.

IEEE Std 1122-1987, IEEE Standard for Digital Recorders for Measurements in High-Voltage Impulse Tests.

IEEE Std C57.12.00-1993, IEEE Standard General Requirements for Liquid-Immersed Distribution, Power, and Regulating Transformers.

IEEE Std C57.12.20-1988, Requirements for Overhead-Type Distribution Transformers, 500 kVA and Smaller: High Voltage 34 500 Volts and Below; Low Voltage 7970/13 800 Y Volts and Below.

IEEE Std C57.12.22-1989, American National Standard for Transformers—Pad-Mounted, Compartmental-Type, Self-Cooled, Three-Phase Distribution Transformers with High-Voltage Bushings, 2500 kVA and Smaller: High Voltage, 34 500 Grd Y/19 920 Volts and Below; Low Voltage, 480 Volts and Below—Requirements.

IEEE Std C57.12.23-1992, IEEE Standard for Transformers—Underground-Type, Self-Cooled, Single-Phase Distribution Transformers with Separable, Insulated, High-Voltage Connectors; High Voltage (24 940 Grd Y/14 400 Volts and Below) and Low Voltage (240/120 V; 167 kVA and Smaller).

IEEE Std C57.12.25-1990, American National Standard for Transformers—Pad-Mounted, Compartmental-Type, Self-Cooled, Single-Phase Distribution Transformers with Separable Insulated High-Voltage Connectors: High Voltage, 34 500 Grd Y/19 920 Volts and Below; Low Voltage, 240/120 Volts; 167 kVA and Smaller—Requirements.

IEEE Std C57.12.26-1992, IEEE Standard for Pad-Mounted, Compartmental-Type, Self-Cooled, Three-Phase Distribution Transformers for Use with Separable Insulated High-Voltage Connectors (34 500 Grd Y/19 920 Volts and Below; 2500 kVA and Smaller).

IEEE Std C57.12.90-1993, IEEE Standard Test Code for Liquid-Immersed Distribution, Power, and Regulating Transformers and IEEE Guide for Short Circuit Testing of Distribution and Power Transformers.

IEEE Std C57.98-1993, IEEE Guide for Transformer Impulse Tests.

3. General test procedures

For information on the correct test sequence when impulse voltage tests are to be performed, refer to IEEE Std C57.12.90-1993.

The routine impulse test normally consists of one reduced and one full-wave impulse, or two full-wave impulses. The full-wave impulses are at a crest voltage equal to the rated BIL of the terminal being tested. Chopped wave tests are not included in the routine test. Each line terminal of a winding rated above 600 V that is brought out through a suitable bushing is to be tested. For transformers that have two or more windings rated above 600 V, all line terminals of each such winding are to be tested. Neutral terminals, and terminals of windings rated 600 V and below, are not to be tested in the routine impulse test.

4. Fault detection methods

Routine impulse testing of distribution transformers as specified in IEEE Std C57.12.90-1993, subclause 10.4 requires that the test equipment demonstrate the ability to detect a single-turn fault. A typical fault can be simulated by placing a shorted turn of wire around the core leg and over the coil of a core and coil assembly. Methods of providing such detection sensitivity are discussed in the sections that follow and in the Annex that accompanies this document.

5. Circuits for routine impulse testing

This test is normally performed on the production line as part of the routine quality control tests. As such, the routine impulse test may be performed on a large number of transformers using a test with automated failure detection. The failure detection system must be sensitive enough to detect all failures, including a single-turn fault.

For a general description of the routine impulse test circuit see the lightning impulse test circuit described in IEEE Std C57.98-1993. Subclause 5.2 of this document describes the recommended circuit hook-ups for various test pieces.

5.1 Impulse wave shape

The impulse wave shape to be used for routine impulse testing of distribution transformers is the ANSI/IEEE standard $1.2 \times 50 \mu\text{s}$ full-wave lightning impulse described in IEEE Std 4-1995 and IEEE Std C57.98-1993. Descriptions of approved techniques and equipment for measurement of the applied impulse wave can also be found in IEEE Std C57.98-1993.

5.1.1 Test voltages

The full-wave impulses shall have a crest value equal to the rated BIL of the terminal being tested. The reduced full-wave impulses shall have crest values equal to 50%–70% of rated BIL.

5.1.2 Tolerances

Tolerances for impulse test voltages and wave shapes are given in ANSI/IEEE Std C57.12.90-1993. It must be noted, however, that it is sometimes not practical to make circuit modifications to achieve a wave shape within tolerance for every transformer being tested. If the impulse equipment is sized to test the required range of transformers and the wave shaping circuit is designed to produce a standard impulse on an average transformer, the test circuit will generally be adequate for making a valid routine impulse test on the full range of transformers.

Every effort should be made to ensure that the applied wave shape complies with the standard in the area of the voltage peak. That is, oscillations on the voltage peak should be no greater than 5% of the crest voltage. If the frequency of those oscillations is greater than 0.5 MHz or the duration of overshoot is less than $1 \mu\text{s}$, the peak voltage value is determined from a mean curve through the oscillation(s). (Refer to IEEE Std 4-1995.)

5.1.3 Effects of impulse generator loading

The impulse equipment used for routine impulse tests on distribution transformers must satisfy a different set of requirements than equipment used for design impulse testing in laboratory environments. Due to the large number of tests that must be performed on a typical production line, impulse circuit parameters can not be modified for each test by changing component values or circuit connections. The impulse circuit, as indicated by Figure 1, should be designed such that it will supply the proper impulse wave shape for all units to be tested without the need to make changes. Depending on the mix of units to be tested on a single production line, such a design may be difficult or uneconomical to achieve. A few guidelines on impulse circuit design for production line testing are given in the following paragraphs.

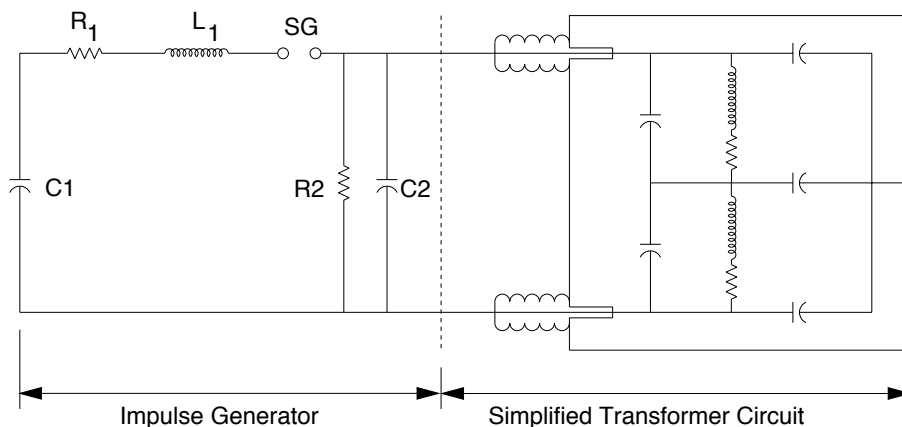

Figure 1—Typical lightning impulse circuit

A large majority of distribution transformers presently produced have a fairly high impedance at the primary terminals when excited by impulse frequencies. As a result the load presented to the impulse generator when performing routine impulse tests on distribution transformers often has only a small effect on the voltage wave shape produced by a well-designed impulse generator. Some transformers however will have a large effect, especially on an impulse generator whose design was not carefully considered.

To provide a more consistent “time to half value” one can use larger stage capacitors and lower value parallel or tail resistors. At the same time, a reduction in the value of front or series resistors will reduce the wave shape distorting effects of variations in load current. Be aware however that reducing the value of front resistors will also reduce front time and may increase oscillations near the wave crest.

As load capacitance changes, so does the impulse front time, often making it difficult to obtain the specified value. The front time is generally determined by the impulse circuit inductances and the RC time constant formed by the front resistors and the circuit capacitances. The two capacitances having the greatest effect are the preload or wave shaping capacitor (C2 in Figure 1), and the effective load capacitance. Since the preload capacitor is in parallel with the load, using a preload capacitance that is much greater than the capacitance of the load reduces the sensitivity of front time to changes in load capacitance. The stage capacitance is in series with the load and preload capacitances and is typically much larger than the preload capacitance. As such, the choice of stage capacitance usually has little effect on front time. Lead inductances and internal generator inductances can, when large enough, have a significant effect on front time. For this and other reasons it is always a good idea to keep all series inductances as low as possible through the use of low-inductive components and short testing leads.

Using good grounding practices also improves the consistency of impulse wave shape and amplitude. For a general discussion on recommended grounding techniques, see section 5 of IEEE Std C57.98-1993.

5.2 Transformer connections

The required connections for routine impulse tests on distribution transformers are defined in subclause 10.4 of IEEE Std C57.12.90-1993. The impulse is applied to one end of a high-voltage winding while the other end of the same winding is connected to ground through a low-impedance shunt or wide-band current transformer. All other windings, the tank and the core are grounded in a likewise manner. A typical connection meeting these requirements is shown in Figure 2. It should be noted that in Figure 2 only one terminal of the non-impulsed winding is connected to ground. The single ground connection to the non-impulsed windings enhances fault detection sensitivity. However, the voltage to ground on any non-tested terminal should not be

allowed to exceed 80% of the applicable BIL. Recommended connections for various types of transformers and a few special considerations are provided in the following paragraphs. The voltage divider and oscilloscope connection as shown in Figure 2 was omitted for clarity in Figure 3 through Figure 20.

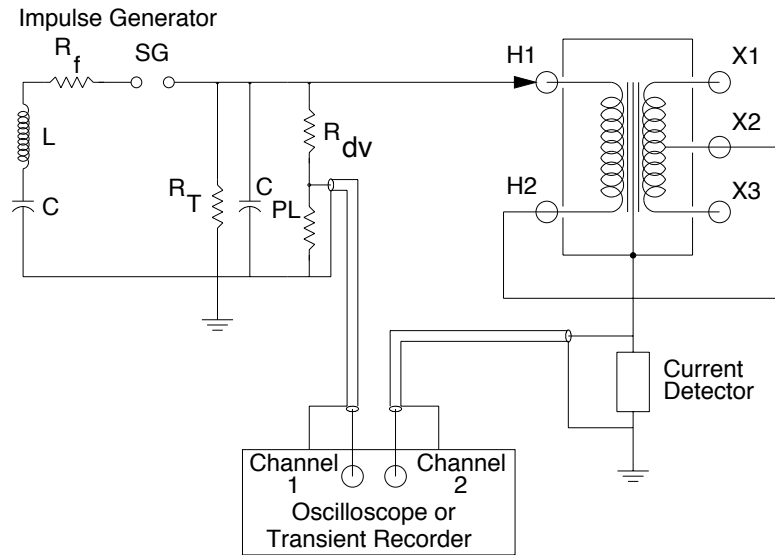

Figure 2—Typical transformer connection for routine impulse testing

5.2.1 Improved fault detection sensitivity

It is generally accepted that one of the more difficult transformer impulse failures to detect is a single shorted turn near the grounded end of a high-voltage, low-kVA, wire-wound primary coil. This type of coil design combines many turns, low volts per turn, and small gauge wire, which are all factors that reduce fault detection sensitivity. Tests on these and other similar units have shown that the sensitivity of the fault detection circuitry to staged faults of this type is increased whenever the tank and one terminal of all non-impulsed windings are connected directly to ground, rather than through the current detector. Routing the tank and low-voltage winding currents through the current detector simply dilutes the fault detection information. A typical connection for greater detector sensitivity during routine impulse tests on distribution transformers is shown in Figure 3.

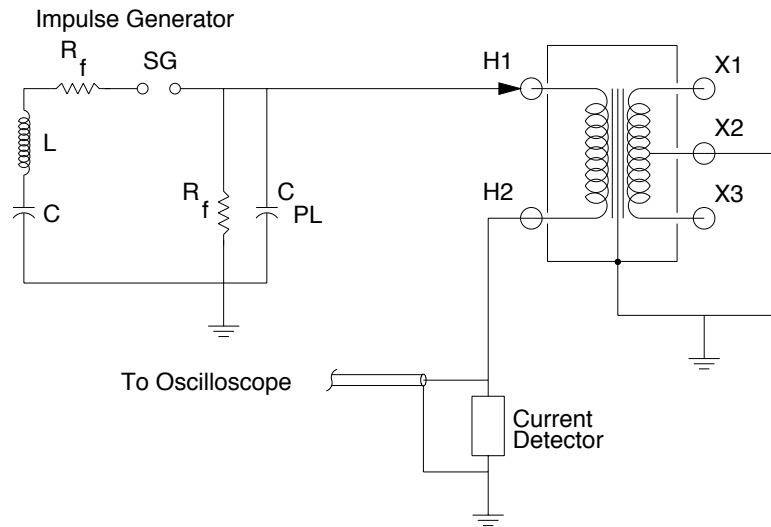

Figure 3—Maximum sensitivity connection

5.2.2 Special cases for single-phase distribution transformers

There are several winding connections for single-phase distribution transformers that require different impulse test connections.

5.2.2.1 Single high-voltage bushing

Figure 4 shows the recommended connection for routine impulse testing of units with one end of the primary or high-voltage winding connected to the tank. The connection for this type unit has the slight disadvantage of routing the tank current through the current detector.

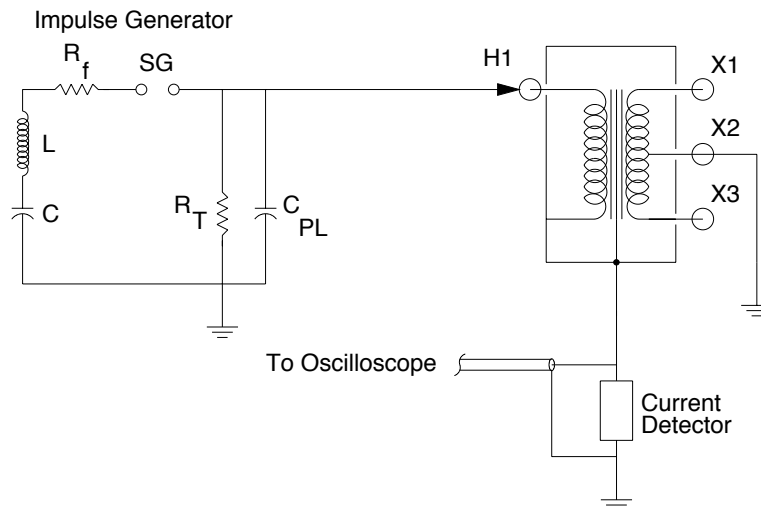

Figure 4—Connection for single HV bushing

5.2.2.2 Internal ground on low-voltage winding

An internal ground on the low-voltage winding reduces the number of external connections required to perform a routine impulse test. See Figure 5 for connection diagram. The connection that should be used for a unit with an internal ground connection on both the low-voltage and high-voltage windings is shown in Figure 6. This connection is much like that shown in Figure 2 except that several external connections are replaced by internal connections.

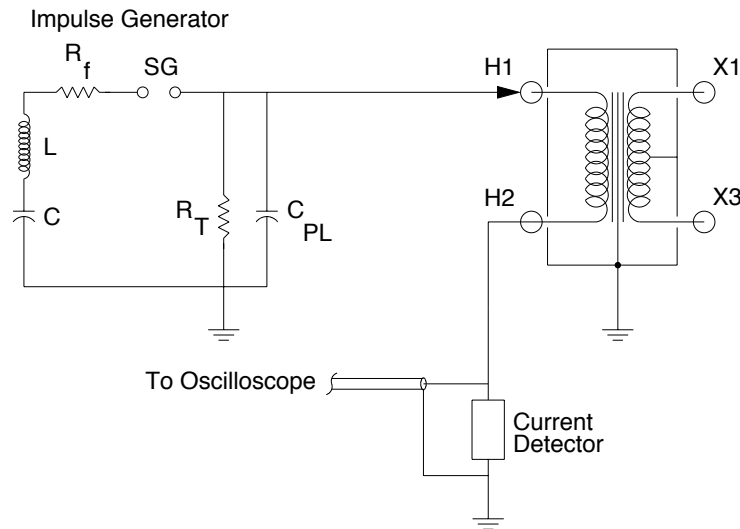

Figure 5—Connections for internally grounded neutral terminal

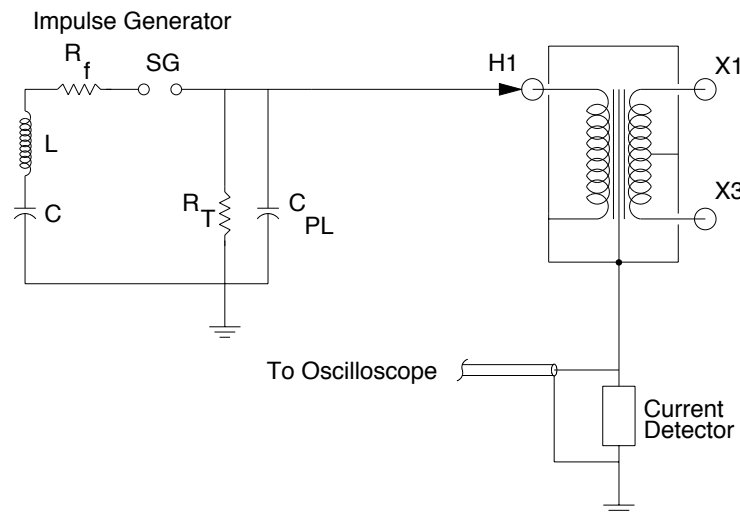

Figure 6—Connections for internally grounded H2 and X2

5.2.2.3 Two low-voltage terminals

On units with only two low-voltage terminals, one end of the winding should be directly connected to ground. Figure 7 shows the recommended connection. For low-voltage windings rated 600 V or below,

either end of the winding may be grounded. Step-down or Intertie units having secondary voltages greater than 600 V may require special consideration when grounding two terminal windings (refer to Subclause 5.2.4 of this document for details).

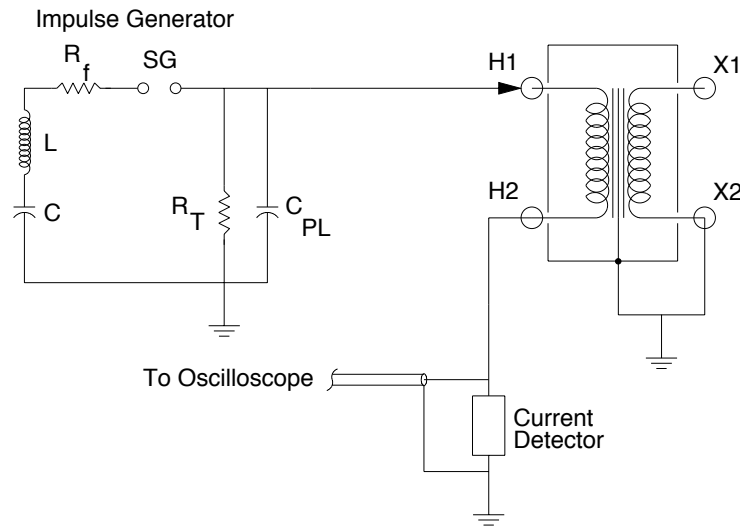

Figure 7—Connections for two large voltage terminals

5.2.2.4 Single low-voltage terminals

Units with only a single low-voltage terminal usually have only one high-voltage terminal.

Figure 8 shows the connection for such a unit.

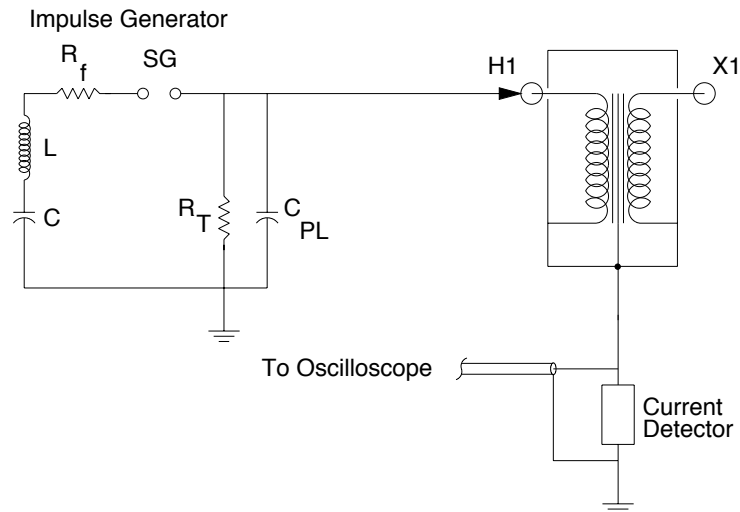

Figure 8—Single HV and single LV bushing connections

5.2.3 Three-phase transformer connections

The most common three-phase connections are described in the following clauses. Transformers with ungrounded wye connected windings that have no accessible neutral point may be tested using the connections for transformers with delta connected windings. Tee-tee connected transformers may be tested using the test connections for wye or delta connected windings that the tee-tee connections simulate.

5.2.3.1 Wye-wye connections

Connections that might be used in three-phase wye-wye distribution transformers are shown in Figures 9, 10, and 11. When possible the connection shown in Figure 9 should be used because it provides the greatest detector sensitivity. On wye-wye units the detector and ground connections are the same for impulses on all three phases. Only one connection is required per phase for routine impulse testing of wye-wye distribution transformers.

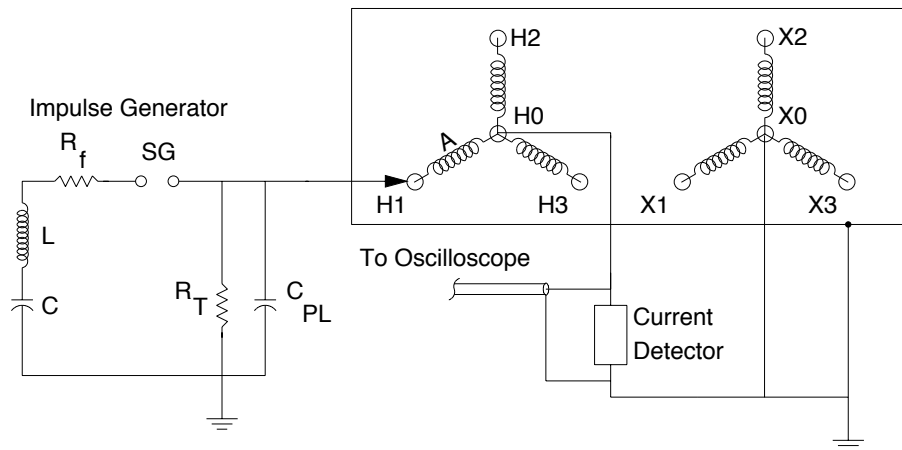

Figure 9—Standard connection for three-phase WYE-WYE transformer

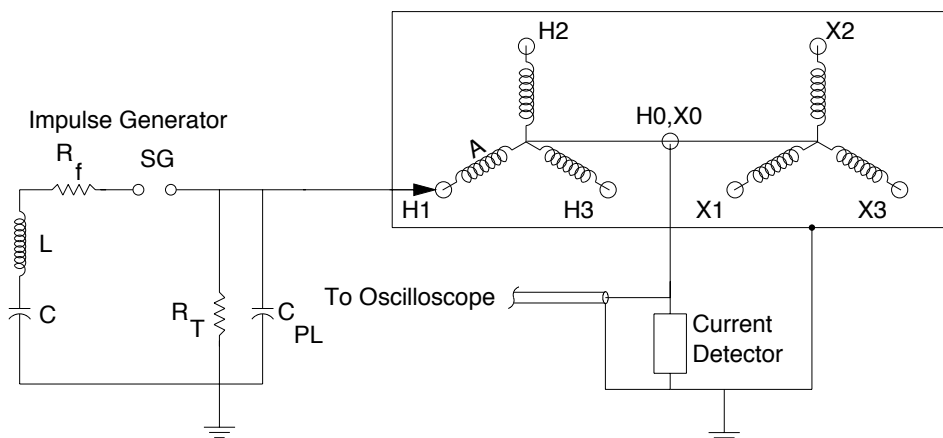

Figure 10—Connections for WYE-WYE transformer with internal HO-XO link

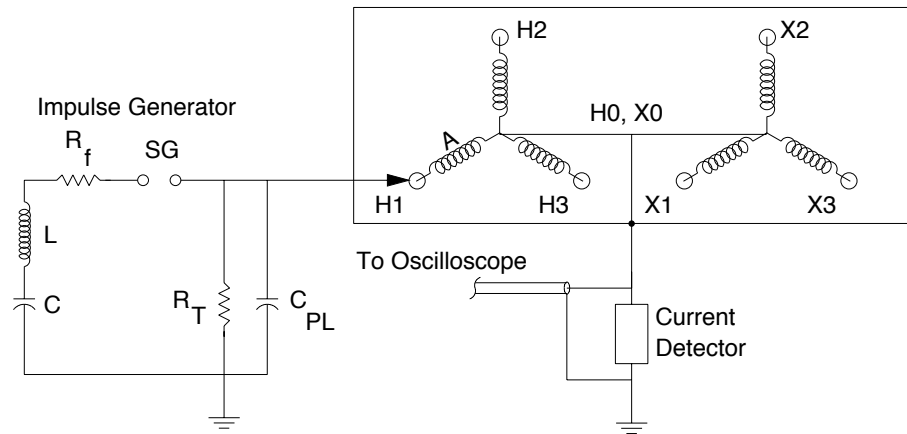

Figure 11—Connection for WYE-WYE transformer with internal grounds

5.2.3.2 Wye-delta connections

Connections for routine impulse testing of phase A on a wye-delta connected three-phase distribution transformer are shown in Figures 12 and 13. Figure 12 is the preferred connection when possible. As other phases are tested the secondary ground connection should be rotated around to other terminals such that one end of the secondary winding of the coil being tested is connected directly to ground. For example when H2 is tested, either X2 or X3 should be grounded, but not both. Only one connection is required per phase for routine impulse testing of wye-delta distribution transformers.

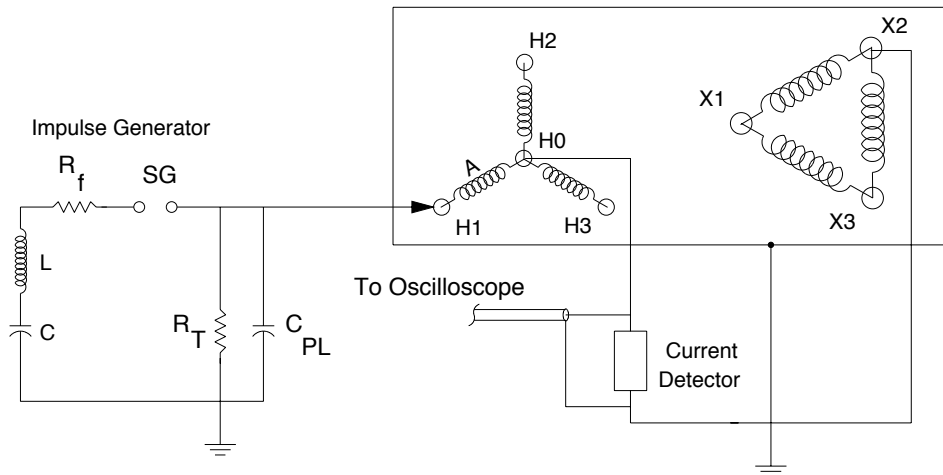

Figure 12—Standard connection for WYE-Delta transformer

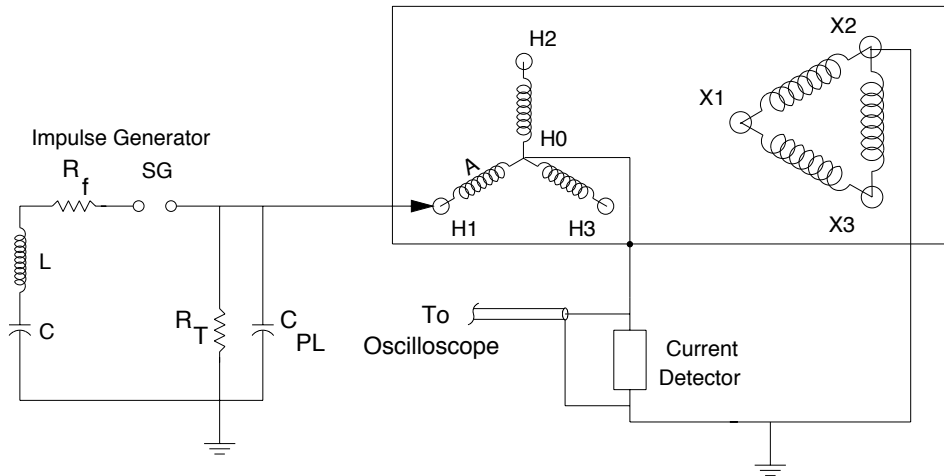

Figure 13—Connection for WYE-Delta transformer with internal HO ground

5.2.3.3 Delta-delta connections

An accepted connection for routine impulse testing of the phase A winding of a delta-delta connected three-phase distribution transformer is shown in Figure 14. Another method of testing the same winding is to connect it as shown in Figure 15. Some manufacturers actually use both connections, performing two impulse tests on each phase of a delta connected primary winding. Using this method provides for each phase winding to receive an impulse from either end. This two-test method requires that a total of six impulse tests be run for each three-phase delta primary transformer.

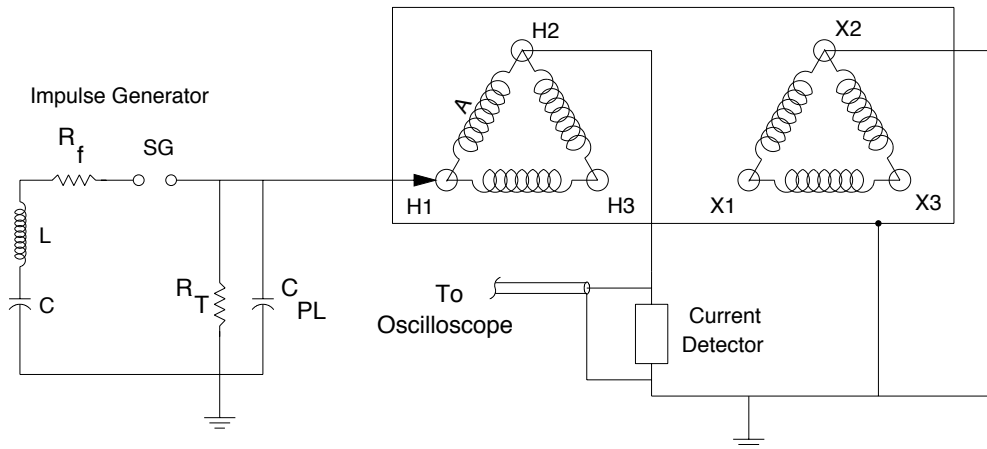

Figure 14—Delta-Delta connections

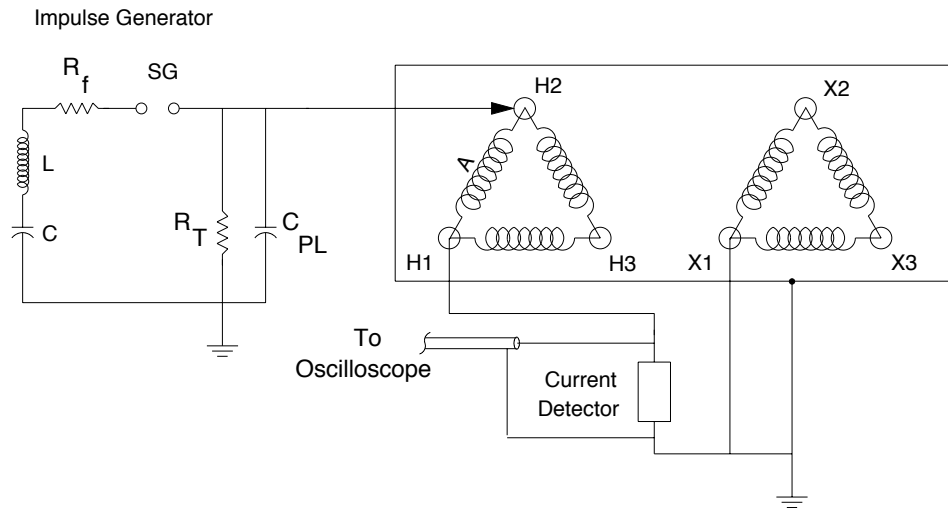

Figure 15—Alternate connection for Phase A on Delta-Delta transformer

5.2.3.4 Delta-wye connections

Figure 16 shows the transformer connection used most often for routine impulse testing of phase A on a delta-wye connected three-phase distribution transformer. The connection shown in Figure 17 is also used for testing the same winding. Once again some manufacturers actually use both connections, performing two impulse tests on each phase of a delta connected primary winding. If the X0 terminal has an internal connection to the transformer tank then the arrangement shown in Figure 18 may be used.

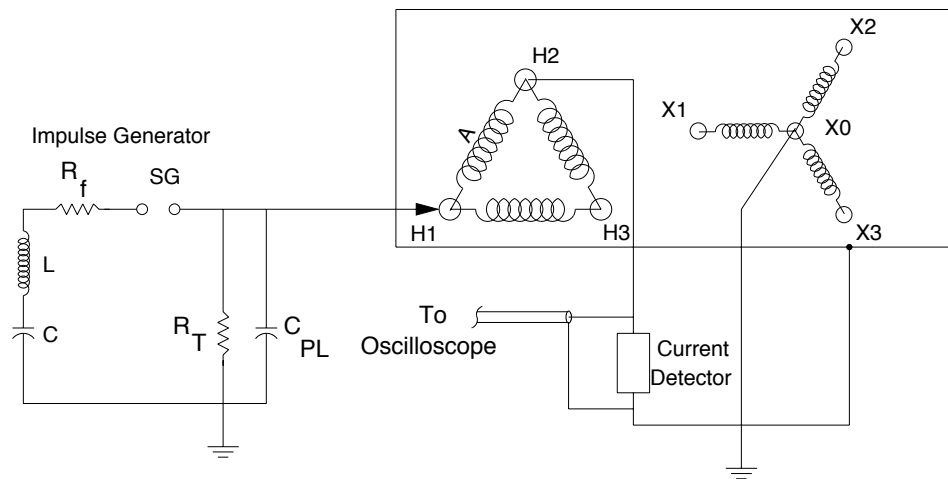

Figure 16—Standard connections for Delta-Wye transformer

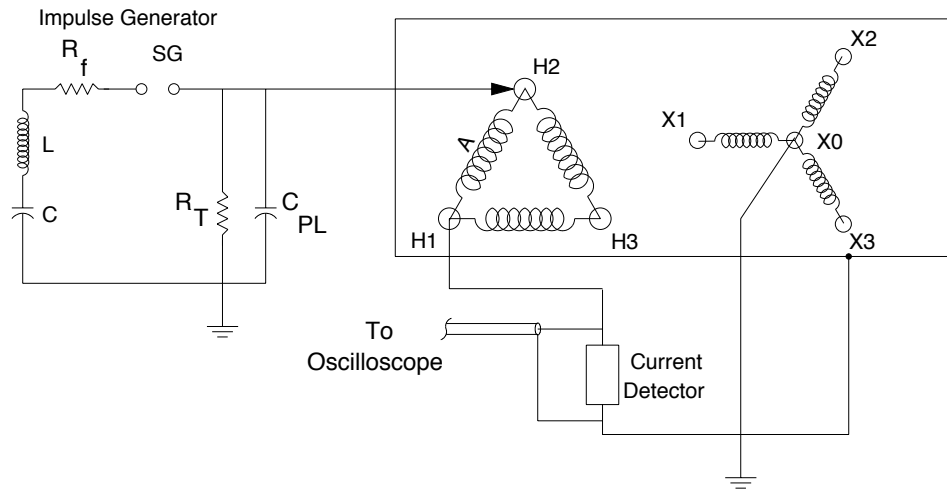

Figure 17—Alternate connection for Phase A on Delta-WYE transformer

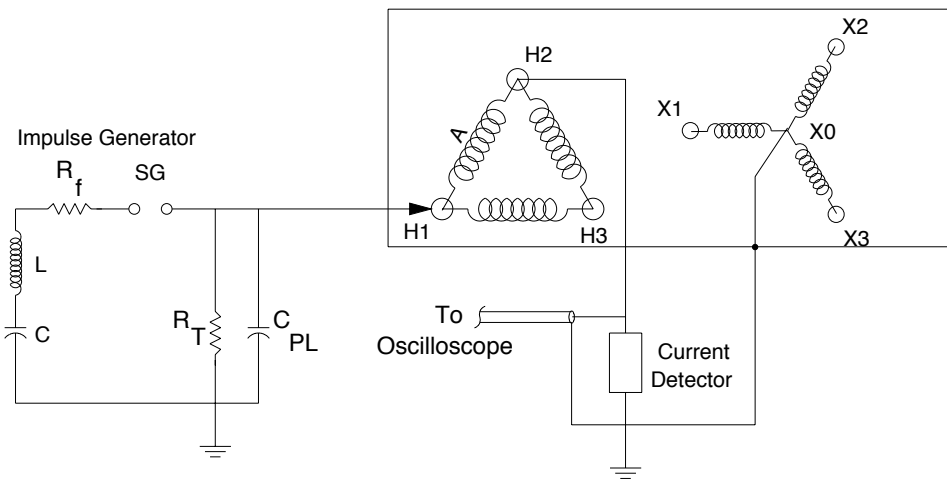

Figure 18—Delta-WYE connections with internal XO ground

5.2.4 Intertie (step) and autotransformer connections

A typical distribution transformer has primary windings rated greater than 600 volts and secondary windings rated 600 volts or less. Impulse tests are therefore only applied to the primary windings. A special class of distribution transformer, the Intertie, has both primary and secondary windings rated greater than 600 V and therefore requires routine impulse tests on both windings. Intertie and autotransformers usually require special test connections when impulse tests are carried out.

5.2.4.1 Limiting induced voltages

The voltage induced on the secondary terminals of distribution transformers during routine impulse testing is typically much lower than the BIL for those terminals. This occurs because the ratio of BIL to rated voltage is much greater at lower voltage levels than at the higher voltage levels. For example, on 600 V windings the ratio between rated BIL and rated voltage is 50 ($30\text{kV}/600\text{V} = 50$), while the BIL/voltage ratio on

high-voltage windings may be as low as 8.7 ($125\text{kV}/14,400\text{V} = 8.68$). In fact, for standard distribution transformers the low-voltage secondary winding BIL/voltage ratio is typically four or five times that of the high-voltage primary winding. As a result the secondary winding insulation is almost always capable of handling induced impulse voltages.

On intertie and autotransformers, impulse testing is likely to induce voltages that exceed the rated BIL on non-impulsed line terminals. For example, a unit with voltage ratings of 14,400–7,200 with BIL levels of 125kV and 95kV has BIL/voltage ratios of 8.7 and 13 respectively. One can see that the BIL/voltage ratio of the lower voltage winding is less than twice that of the higher voltage winding. If the normal routine impulse connection was used on this unit, a full-wave impulse applied to the lower voltage winding would be likely to induce voltages in the higher voltage winding greater than that winding's BIL.

A full-wave application to the higher voltage winding of the above mentioned unit would not induce voltages of the same magnitude, but could cause non-impulsed terminals to exceed their recommended voltage levels. Therefore, in the case of these special transformers, the voltage levels likely to be induced at the line terminals of the non-impulsed windings should always be determined prior to the application of full impulse voltage.

5.2.4.2 Voltage limiting resistor

Section 10.4 of ANSI/IEEE C57.12.90-1993 allows resistors to be connected between the non-impulsed line terminals and ground, to limit induced voltages on those terminals to 80% of the applicable BIL. Any resistor used should have an adequate voltage rating, be non-inductive and have as high an ohmic value as possible that serves to limit the induced voltage. A typical range of resistor values is from $200\ \Omega$ to $2000\ \Omega$. Figures 19 and 20 show transformer connections used when voltage limiting is required. It should be noted that any load placed on the winding in this manner increases the neutral current through the detector circuit and therefore reduces fault sensitivity. The standard method of fault detection is sufficient in most cases; however, closer scrutiny than normal is suggested. When possible, other methods of fault detection such as comparison of before and after exciting current tests and induce tests should also be employed.

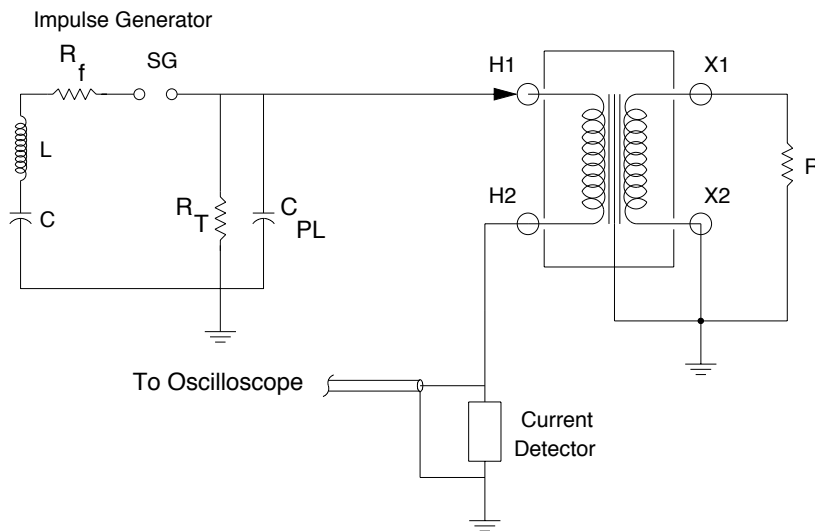

Figure 19—Connection to limit secondary voltage

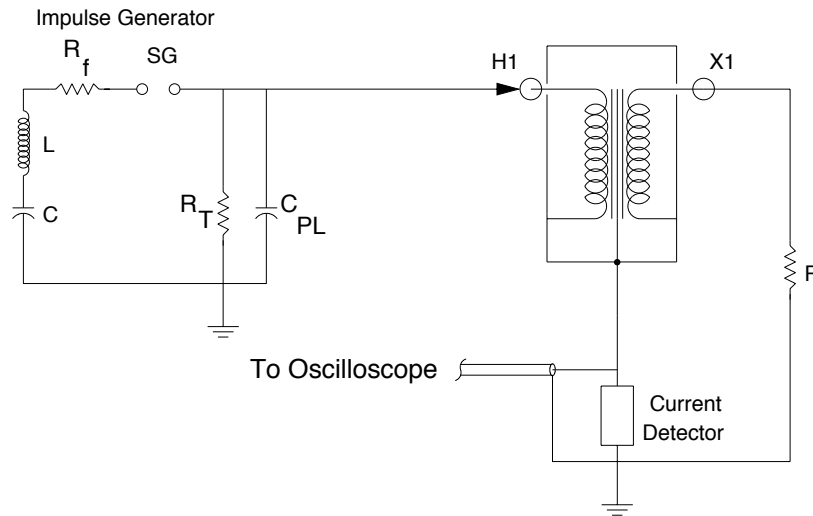

Figure 20—Connection to limit secondary voltage with internal grounds

5.3 Grounding considerations

Impulse guide IEEE Std C57.98-1993 describes recommended grounding methods for impulse testing. The factory environment has the effect of making proper grounding more important and more difficult. The neutral-impedance method of fault detection allows a major reduction in detector bandwidth; therefore, high-frequency noise can be filtered out. However, major ground potential shifts due to improper grounding may affect fault detection or destroy electronic detectors.

6. Neutral current detection circuit

The best known method of fault detection for distribution transformers utilizes neutral current wave shape comparisons. In this method the current from the non-impulsed terminal or grounded end of the high-voltage winding is routed through a detector circuit. For the single high-voltage bushing transformer, the tank and core ground currents are also routed through this circuit, along with the winding current.

There are two types of neutral current detection methods commonly used in transformer impulse tests, (a) the ground-current method and (b) the neutral-impedance method. It is the relative values of resistance and capacitance used in the shunts or connected across the output of the wide-band current transformers that qualify them as either ground-current or neutral-impedance detection methods. Low values of resistance and capacitance characterize the ground-current method with a lower time constant and higher bandwidth than the high-value components used in the neutral-impedance method. The method to be used depends upon which components of current are considered most important for fault detection (refer to IEEE Std C57.98-1993, section 2.9, “Ground Current Traces”). The circuits employed in the two methods are described in the following sections and in the annex at the end of this document.

6.1 Ground current circuit

A suitable non-inductive resistor or wide-band current transformer is used to examine the impulse current waveform of the winding under test. To limit the magnitude of the initial capacitive component of current, a capacitor should be connected in parallel with the resistor or, in the case of the current transformer, connected in parallel with its output. The capacitance value selected should be no greater than that required to

provide adequate oscillographic deflection of all components of the impulse current (refer to IEEE Std C57.98-1993, section 3.5, "Failure Detection").

In the case of a typical lower kVA distribution transformer, the magnitude of the initial pulse may be 1000 times greater than the subsequent inductive component of the waveform. This requires that both the parallel capacitor and the resistor be relatively large. The parallel capacitor and resistor circuit is then called a neutral impedance. As discussed in other sections of this document, the neutral-impedance method is considered to be the more sensitive method of detecting the failures that may occur during impulse testing of distribution transformers.

6.2 Neutral-impedance circuit

The neutral impedance is usually a parallel connected R-C shunt. The voltage output of the shunt can be fed into an oscilloscope or digital recorder for subsequent wave shape comparison. Figure 21 shows a switch-selectable arrangement of three such shunts. The capacitor serves to absorb the initial spike of capacitive current flowing through the transformer winding during the first few microseconds of the impulse. It then integrates the total current, which is mainly inductive in nature, that flows for the remainder of the impulse. The parallel resistor serves to limit the voltage across the shunt to a reasonable value for detection and to discharge the capacitor. It is also a good idea to include a spark gap or surge suppressor to limit the voltage across the shunt in the event of a major failure to ground in the transformer under test. Operation of the over-voltage protective device is also an indication of transformer failure.

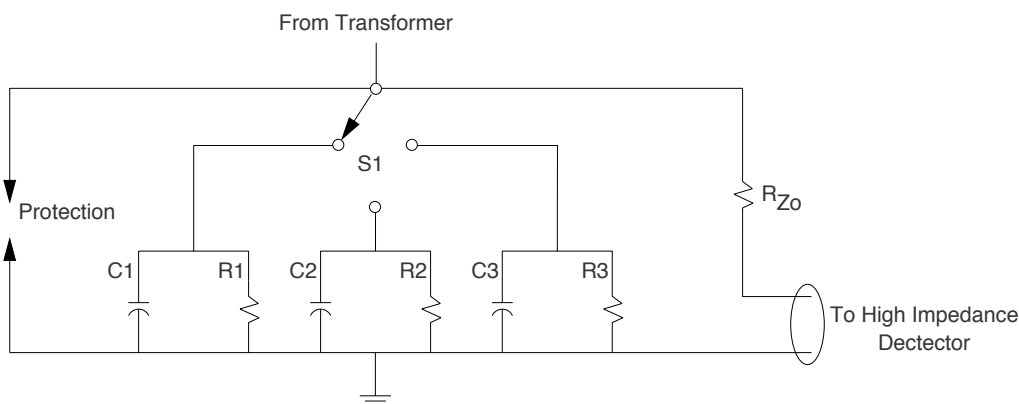

Figure 21—Natural impedance current detector circuit

The values for R and C in the shunt depend upon the design of the particular transformer under test. While one set of shunt elements may be suitable for a particular series of transformer designs, several sets may be required to test the full range of distribution transformers covered by this practice.

The shunt elements are generally chosen to provide a peak voltage of about 700 to 1000 V, which is mainly controlled by the capacitor value. The larger the value of capacitance, the smaller the voltage across the shunt. Typical values of capacitance range from 0.05 microfarads to 2.0 microfarads. The resistor value is then chosen to achieve a voltage decay to half value in the 50 to 2000 microsecond range. The larger the value of R, the longer the decay time and often the better the sensitivity.

A properly designed shunt will allow easy detection of transformer faults by observation of an increase in magnitude of the peak value of the voltage across the shunt, or by a rise in the tail of the wave shape.

6.3 CT circuit

This section describes a neutral-impedance method utilizing a current transformer. Referring to Figure 22, a current transformer is placed in the ground return path between the transformer under test and ground. The output of the current transformer is applied to a resistor/capacitor network. The output of the network is sent to a recording device.

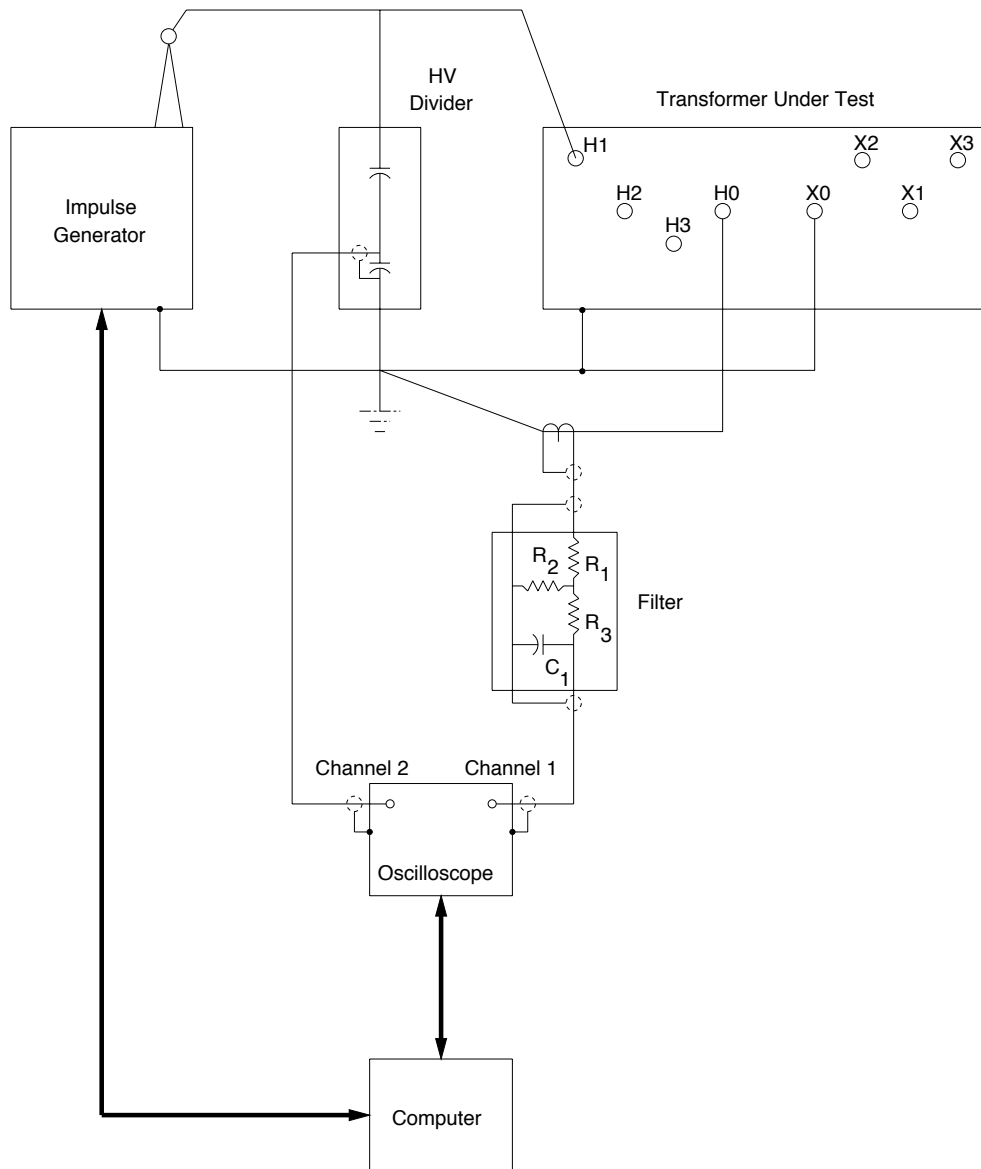

Figure 22—CT type current detector circuit

6.3.1 Current transformer selection

The CT should be a precision wide-band type, with a rise-time rating of 20 nanoseconds or less and a droop of less than 0.1% per microsecond. Risetime is a measure of the CT's ability to respond to the high-frequency components of current and droop is a measure of the response to low-frequency components.

The maximum peak current rating of the CT, together with the current times time product (I^*t) rating, should be chosen so that core saturation does not occur during normal unfaulted operation or during minor faults, such as those involving single turns. Core saturation could lead to wave shape distortion and erroneous indication of test object failures. The I^*t rating of a CT is the product of current and time in amp-seconds, based on a rectangular current pulse. For the actual impulse current passing through the window of the CT, the I^*t is the area between the actual impulse current and its horizontal axis. To avoid saturation, the area under the curve of the actual impulse current should be smaller than that specified for the CT being considered.

Where the magnitude of the fault would be obviously indicated by the voltage wave shape, as in the case of major layer-to-layer faults involving multiple high-voltage turns and practical constraints can be placed on the rating of the CT, then the peak current and I^*t ratings may be exceeded. The CT manufacturer should be consulted to help choose the best model for the application and for circuit design recommendations. A typical rating would be 2000 amperes peak, 500 milliamperes-seconds, and 30 kilovolts isolation.

These CT's generally have an internal resistance, the value of which makes them suitable for use with coaxial measuring cables of a particular impedance, for example, 50 or 75 Ω . If long measuring cables will be used, the CT should be selected to have the same source impedance as the impedance of the measuring cables.

6.3.2 Circuit design

The CT in Figure 22 produces an analog output voltage signal proportional to the primary current through the loop of the CT. This analog voltage is applied across resistors R1 and R2 where $R1 + R2$ equals the characteristic impedance of the coaxial cable. R3 is chosen to be much greater than R2 so that the current flowing through R1 is approximately proportional to the impulse ground current. The ratio of R1 to R2 plus R1 is chosen to provide the correct amplitude for the recording device. Values for R3 and C1 are chosen to give a wave shape that is particularly sensitive to a single-turn fault. This wave shape is captured by a recording device.

7. Failure detection methods

Any detection system that detects all impulse faults, including single-turn faults, is acceptable and is not limited by the methods explained in this document.

7.1 Detection requirements

The failure detection scheme used for routine impulse testing must be capable of detecting all faults within the transformer that occur as a result of the impulse test. The required sensitivity is the ability to detect a single shorted turn within the winding. Generally, this is the most difficult type of fault to detect, especially in small kVA transformers with high primary voltages.

For high-volume production, it may be desirable to have an automated failure detection system. Such a system would give an indication if a failure occurs during the impulse test. A system like this typically uses a computer to compare voltage and/or current wave shapes from two test impulses to determine if a failure has occurred. Also, comparison with reference wave shapes, both with and without staged faults, may be used for calibration and sensitivity adjustment.

In addition to some of the more sensitive methods of failure detection discussed in this guide, other classical methods can be used to detect more severe breakdowns. These include chopping of the applied voltage wave, large ground or neutral currents, flashover of shunts, loud noise, etc. If automated methods are employed for failure detection, these other methods may be incorporated into the overall detection scheme as well as the more sensitive wave shape comparisons.

7.2 Comparison of wave shapes

Subclause 10.4.2 of IEEE Std C57.12.90-1993 [10] recognizes two methods of failure detection using wave shape comparison. In method 1, subclause 10.4.2.1, one reduced full-wave test is performed followed by one 100% voltage full wave. The wave shapes of either the ground current or the voltage across the neutral impedance from the two tests are compared. Differences between the two wave shapes, other than relative magnitude due to the different applied impulse voltage, may be an indication of failure. The threshold level for a failure is determined by taking reference shots on transformers of similar design to those being tested, both with and without staged single-turn faults.

In method 2, subclause 10.4.2.2, two 100% voltage full-wave tests are applied to the transformer under test. The wave shapes of either the ground current or the voltage across the neutral impedance from the two tests are then compared to other wave shapes of known good transformers of similar design. Generally, a rise in the tail of the neutral-impedance current wave is an indication of failure.

7.3 Automatic failure detection

Several hundred impulse tests per day may be required in a high-volume production facility. An automatic failure detection system is desirable because it reduces operating costs and identifies transformer defects. Automatic detection is accomplished either by discrimination of curve amplitude using an analog or digital detector or comparison of curve areas using a digital detector. Figure 23 is a record from a test on a transformer using a neutral impedance. The fault is easily detected visually, and automatic detection would be possible.

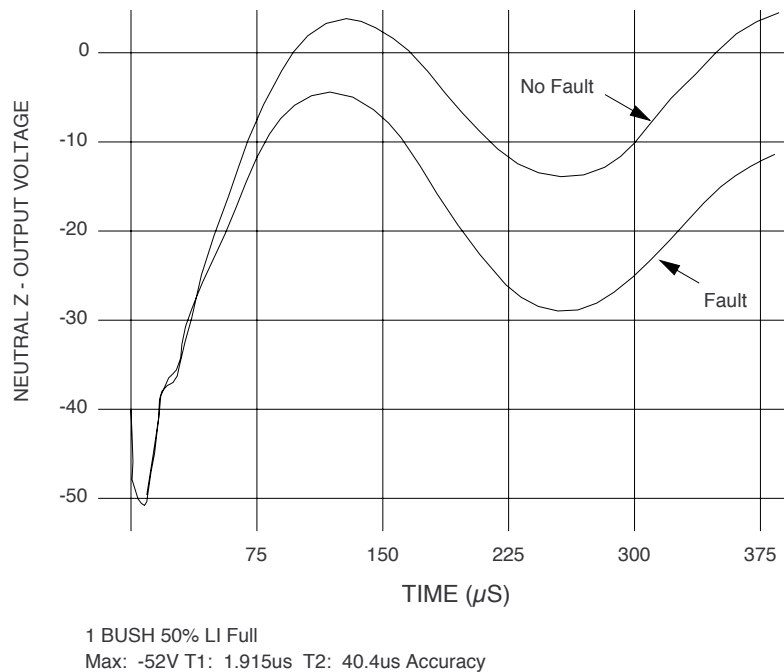

Figure 23—Comparison of neutral-impedance curves

7.3.1 Analog systems

Figure 24 is a circuit for automatic fault detection. The functional components are the RC shunt, the LRC filter that acts as second integrator, and a thyatron tube circuit that serves as a variable voltage level detector.

The circuit components can be optimized for the transformer being tested, but there is a wide range of values that work for each transformer and the full scope of distribution transformers can be tested with only a half dozen or so of the RC shunts and filters. This circuit as shown requires that a setup be made on a known good transformer and then, if the integrated current on the test piece exceeds the setup by more than a set amount (20% typical), a failure is indicated. It also requires that the transformer being tested be isolated from ground and connected to the neutral shunt so that all current will flow to the fault detector and any fault will tend to increase the current magnitude.

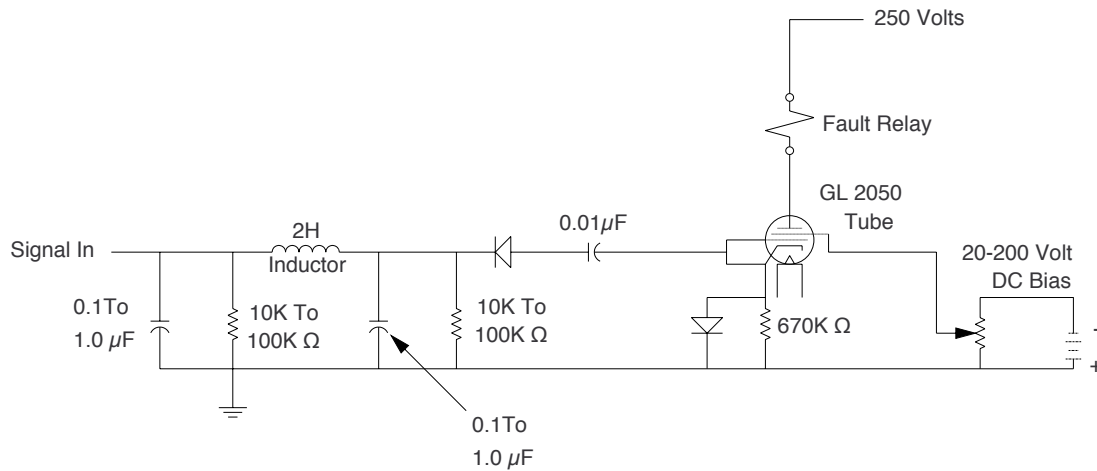

Figure 24—Analog fault detector

Figure 25 shows the signals at the voltage level detector when the neutral-impedance curves are as shown in Figure 23. The detector bias would be set to fail the lower, more negative curve and pass the higher curve.

Figure 26 is an automatic fault detection circuit similar to Figure 24. This circuit is adapted to making a comparison of a reduced wave to a full wave on the same transformer. The integrated currents are stored and compared. If after the test wave the comparator output is sufficient to energize the detector, a fault is indicated. An additional condition for proper detector operation is that the ratio of the reference and test impulse amplitudes be known so the signal levels to the comparator are properly scaled.

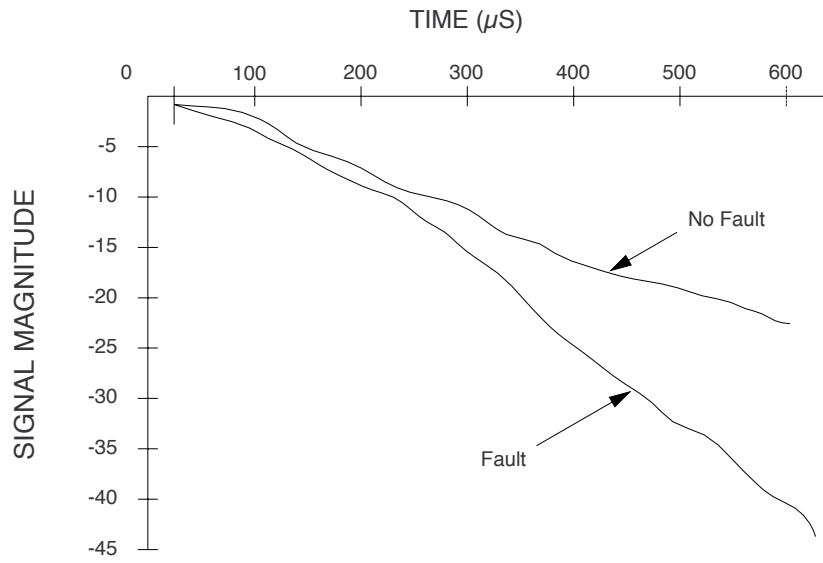

Figure 25—Signal into detector voltage sensor

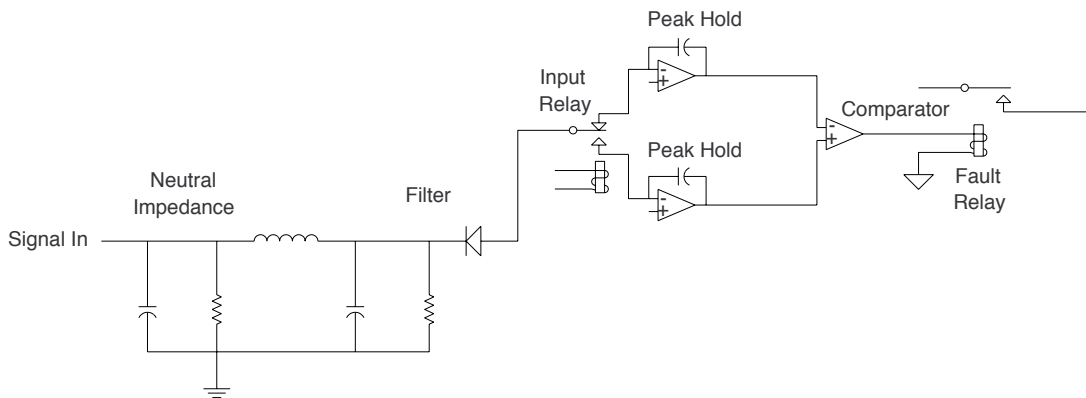

Figure 26—Fault detector with immediate comparator

7.3.2 Digital systems

The high sensitivity and low-frequency content of the signal provided by a neutral-impedance shunt can reduce the measuring constraints placed on any digitizing oscilloscope used to monitor this signal. Providing that a digital recording system has sufficient resolution to adequately display the impulse voltage and current results, then the 10 bit vertical resolution recommended for impulse wave shape comparison tests need not apply.

The frequency content of a standard lightning impulse full wave becomes insignificant above 1 or 2 MHz, while the long time constant of the neutral-impedance shunt limits that signal's frequency content to typically less than 250 kHz. The maximum single-shot sampling rate required for a suitable digital oscilloscope would therefore be, as specified in IEEE Std 1122-1987, 60 megasamples per second.

Note that the 60 MHz sample rate is only required to be used during measurement of the impulse risetime, or when scrutinizing the impulse records for small aberrations that are of a similar time duration. Once the risetime has been determined, the sample rate can be reduced, being based on the oscilloscope's ability to display a fault and to make repeatable measurements of the peak voltage. A reduced sample rate has the advantage of requiring less memory or record length for a given sweep length. This further reduces digitizer constraints and also limits the amount of data required to be processed.

An 8 bit scope with a 60 MHz sample rate would have the resolution and speed to record the impulse voltage and current. However, an off the shelf test bench oscilloscope will produce erroneous results and not last long unless it is well protected from the typical factory environment and impulse EMI. In many cases it would be better to buy a product built for impulse testing rather than spend a considerable amount of effort hardening a test bench scope and writing the software that would enable it to become a part of a routine impulse test system.

Several impulse test equipment manufacturers can provide impulse oscilloscopes or impulse measuring systems that have been hardened to the impulse laboratory environment. These systems capture the impulse curves, store them, display them with editing capabilities, analyze them in time or frequency domain, and print the results. They are computer based and either come with a personal computer or can be interfaced to a personal computer. Because the systems are single purpose and have a limited market, the ability to customize is stressed. The vendor either provides custom software or provides a means of tailoring the standard software to the application and interfacing application software to it.

A digital measurement system used as a fault detector has several advantages over an analog system. One major advantage is the flexibility. Once an analog detector is built, any significant changes require that the equipment be taken out of service and rewired. A digital system is changed by installing a new program. Another advantage is the ability to store test data for later analysis. If a fault occurs on an automatic system, the data can be saved for manual interpretation of the fault. The computer or computer interface that is normally provided with a digital system simplifies the integration of the fault detector into an automatic test system. But probably the greatest advantage is the ability to use mathematical manipulation of the digital data to increase the sensitivity of the fault detector.

Fault analysis with a digital system starts with processing data points of the reference and test curves. The curves representing the impulse current contain the fault information, and to do anything with these curves they must be matched in time and scaled in amplitude. This is not a trivial task. First, the exact amplitude of the current is not known, and a conservative estimate of the amplitude may result in the curve being much less than half the full range of the instrument. Secondly, if a fault occurs, the current amplitude will be affected. Both these factors make it less desirable to use the current curve data points to match up the curves. Figures 27 and 28 show how the current curves can be improperly compared. Figure 27 shows the lower curve to be about 100 mA at positive crest but Figure 28 shows the original lower curve of Figure 27 to be 187 mA.

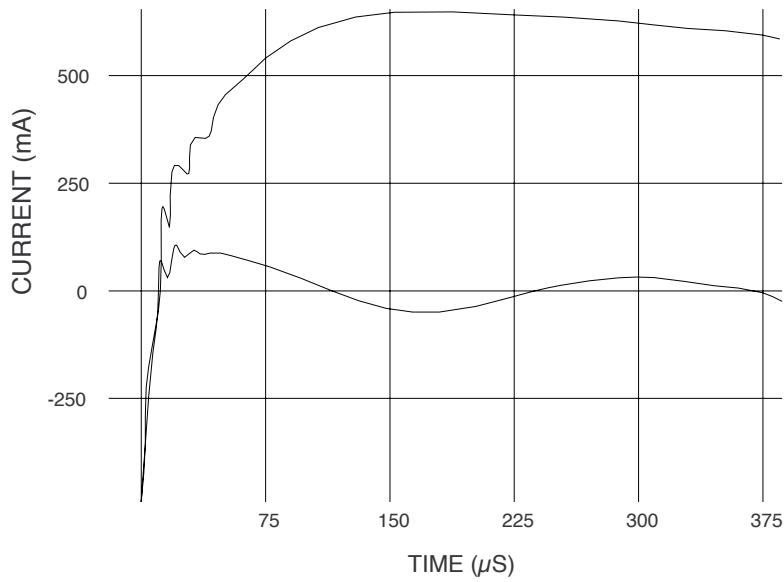

2 BUSH FMG 50% LI Full
Max: 656mA Min: -500mA Accuracy

Figure 27—Current comparison mismatch

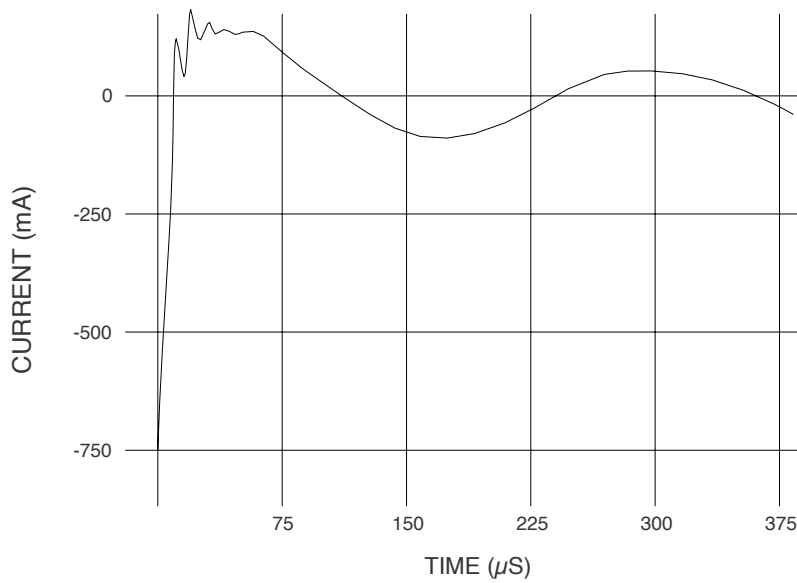

2 BUSH 50% LI Full
Max: -875mA Min: 187.5mA

Figure 28—Current curve no fault

A better method is to use a two-channel system, capture the applied voltage curves, which are of a known amplitude and form, match the voltage data points, and use the timing and scaling information to match the current curves. This, of course, requires that the two channels be sampled simultaneously and that the data files be related. If it is impossible to match the voltage curves, a major fault has occurred and no additional

analysis is required. Figures 29 and 30 show the voltage and current curves on a transformer failure. Analysis of the applied voltage wave shape indicates a major insulation failure.

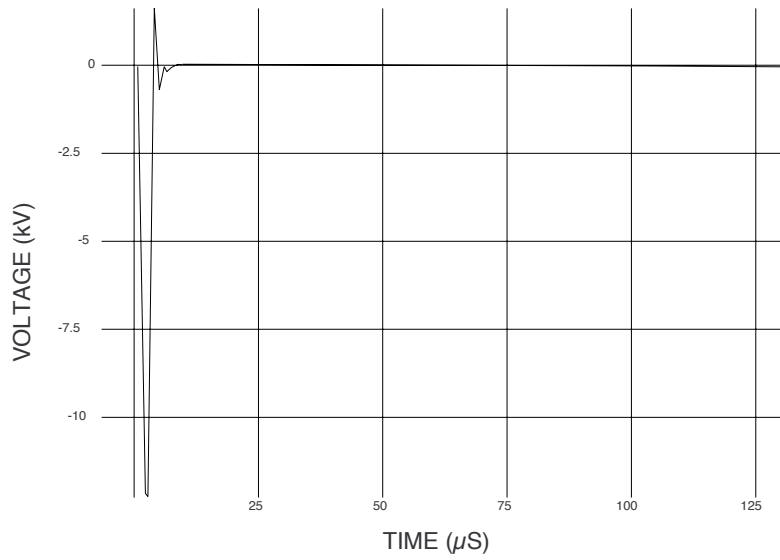

2 BUSH FHG LI Full

Max: -12.5 kV Min -15.3% T1: 644 nS Tc: 787 nS Accuracy

Figure 29— Voltage curve, ground fault

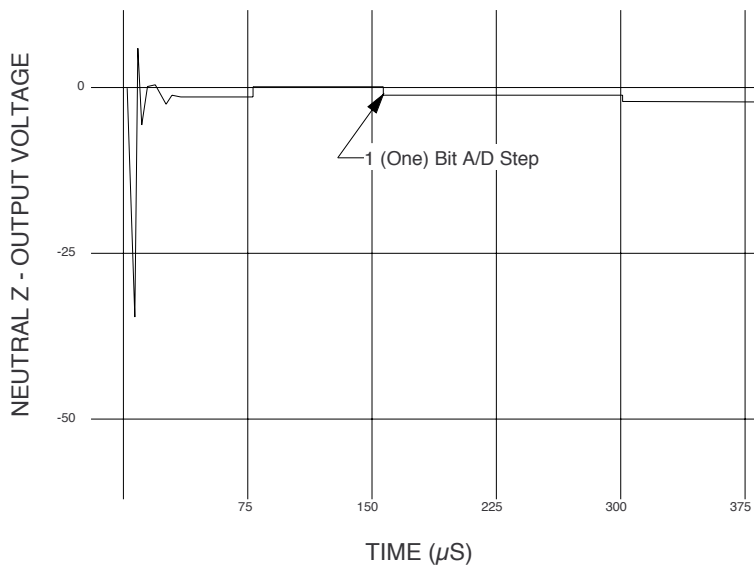

2 BUSH FHG LI Full

Max: -64 V Min -21% T1:729 nS Tc: 741 nS Accuracy

Figure 30—Current curve, ground fault

Figures 31 and 32 show another failure but the breakdown occurred after the half crest point. A major insulation failure is again indicated by simple comparison of the applied voltage wave.

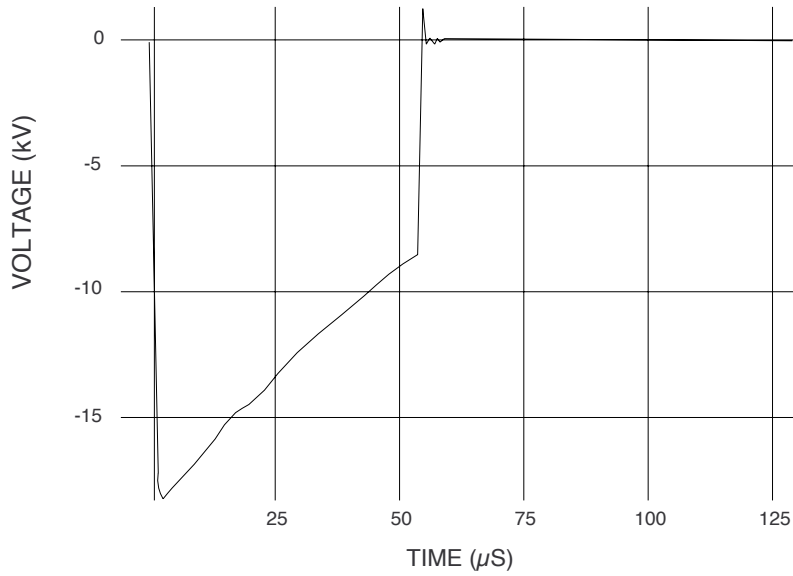

2 BUSH FHG 50% LI Full
Max: -18.3kV Min: -7.4% T1: 1.308 μS Tc: 54.4 μS

Figure 31—Voltage curve, ground fault

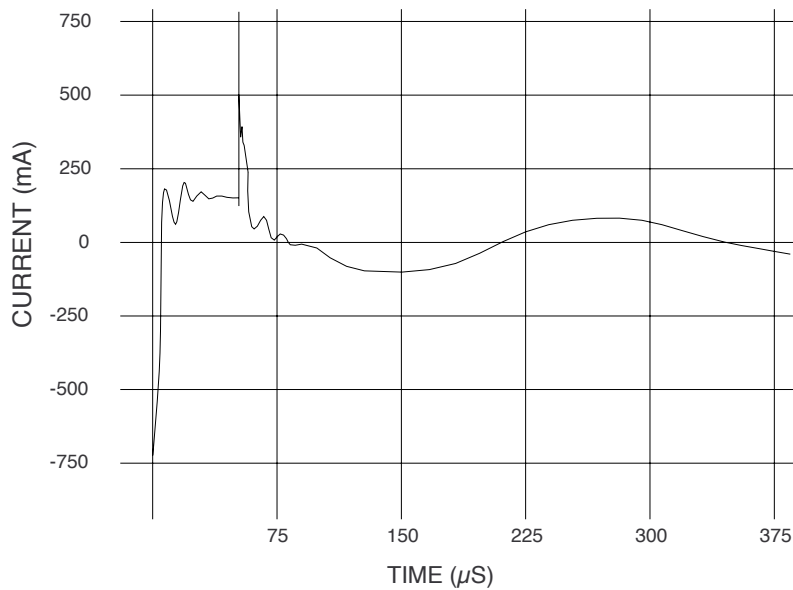

2 BUSH FHG 50% LI Full
Max: -894mA Min: 809mA

Figure 32—Current curve, ground fault

Figures 33 and 34 show the comparison of reference and test curves for a primary to secondary failure. The voltage curves barely indicate a failure, but the current curves show a failure that involves a major portion of the winding. A simple comparison of the current waves would find this fault in all transformers. In this case the neutral-impedance shunt was 0.1 microfarads and 100k ohms, and the primary winding was isolated from the tank.

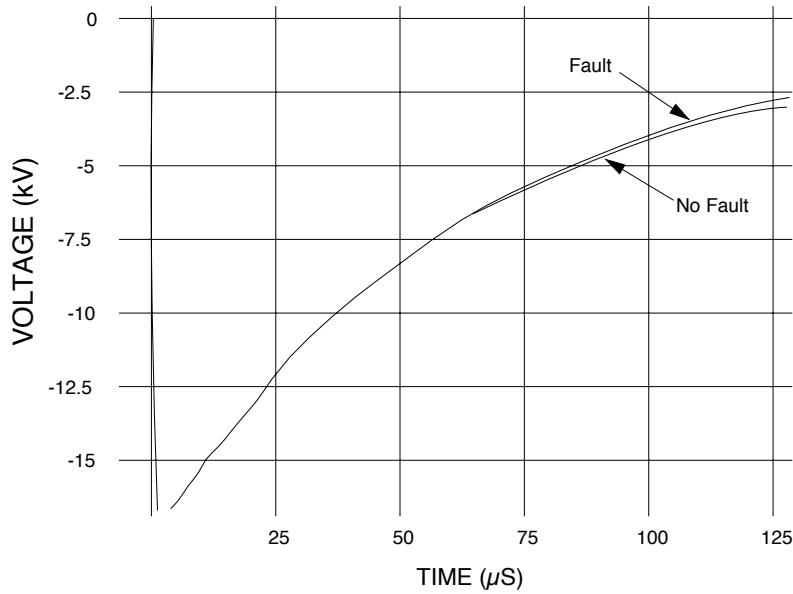

Figure 33—Voltage curves, fault to secondary

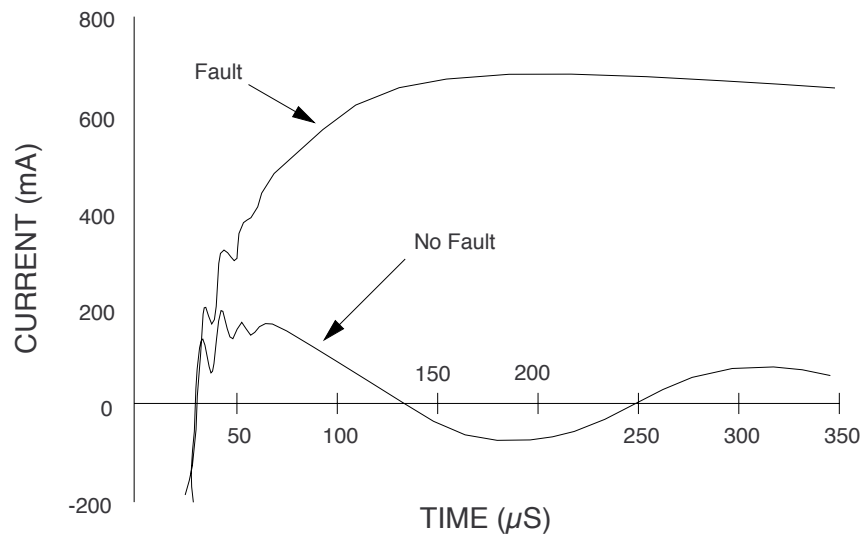

Figure 34—Current curves, fault to secondary

7.3.3 Single-turn fault detection with a digital system

The curves in Figure 34 demonstrate failures that are easy to detect manually by comparison of the raw current and applied voltage curves. They also can be automatically detected by subtracting the test curves from the reference curves. If the absolute difference is more than a predetermined percentage of full-scale or maximum curve amplitude, a failure is indicated. Sometimes the fault will occur between two adjacent turns. Figure 35 shows the comparison of current curves on a small transformer with and without a one-turn fault. The difference in the curve caused by the fault can be relatively large as in the case of a higher kVA, lower primary voltage transformer, or it can be vanishingly small as in the case of a 5 kVA, 34 kV transformer. Another difficult fault to find is between different strands on a multistrand conductor winding.

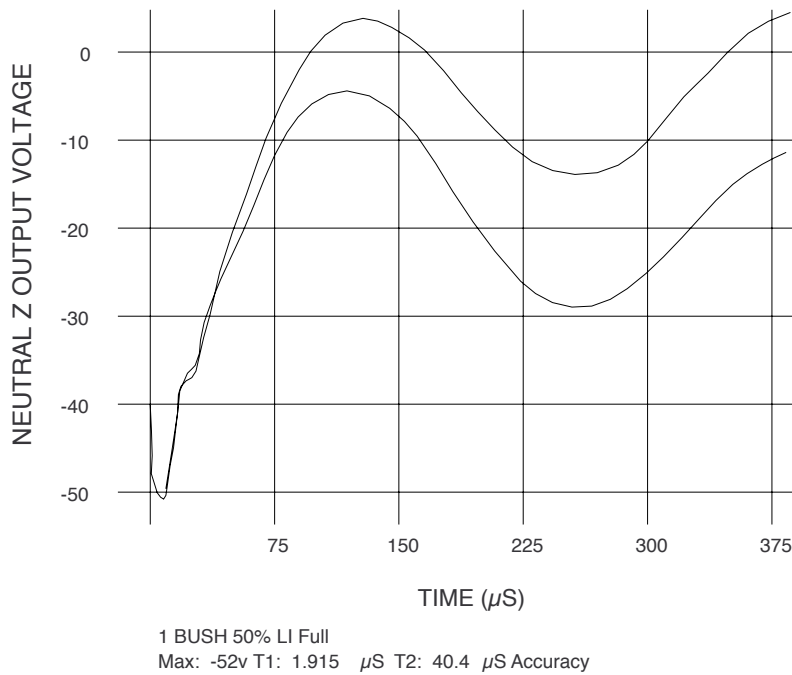
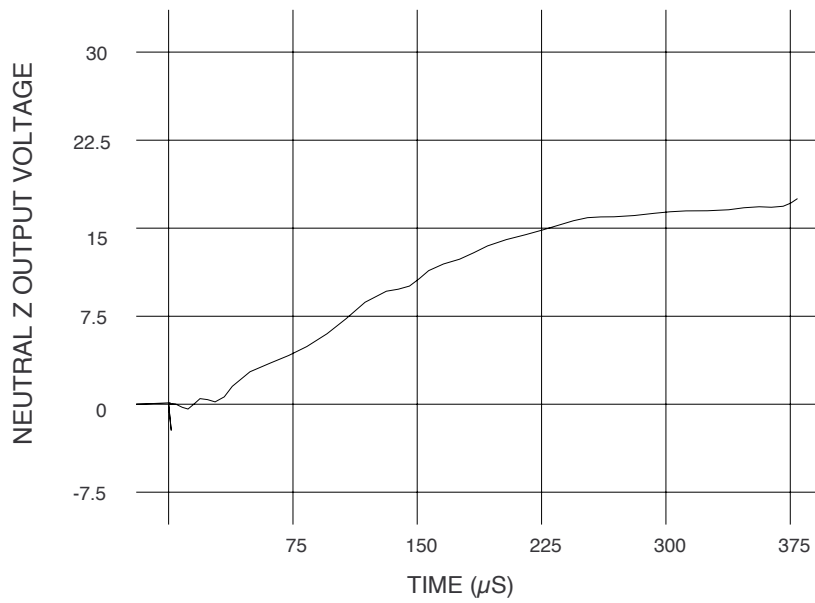

Figure 35—Neutral impedance curves, comparison of single-turn fault

The neutral-impedance voltage curve can vary from an overdamped exponential to a damped oscillation. Significantly, a faulted turn or several faulted turns results in more negative current throughout the first 200 microseconds or more of the impulse wave. The neutral-impedance curve may not change shape enough to be obviously different but will have a dc offset. The accumulative effect is always significant. Figure 36 shows a difference from the comparison made in Figure 35. Figure 37 shows the accumulative difference. The neutral-impedance shunt was 0.1 microfarad and 100k ohms, and the primary winding was connected to the tank.



1 BUSH 50% LI Full
Max: -52V T1: 1.915 μS T2: 40.4 μS Accuracy

Figure 36—Neutral impedance curves, difference of single-turn fault

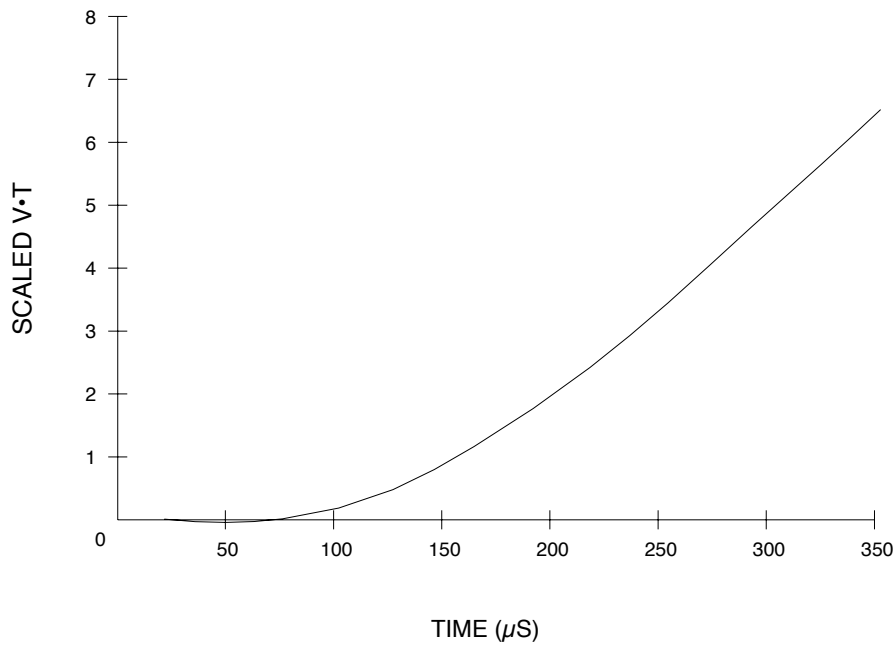

Figure 37—Neutral impedance curves, accumulated difference

The compared curves of Figure 35 track together for the first 30 microseconds and then deviate for the next several hundred microseconds. This is typical of what will occur for any winding fault on any distribution transformer. If there is no useful information in the first part of the neutral-impedance curve, those data points need not be included in the analysis. The difference between the neutral-impedance curves should be

accumulated for the remaining part of the first 300 or 400 microseconds after the start of the impulse wave. The applied voltage curves need to be compared for about 150 microseconds. These are conservative estimates, and with more experience the amount of data to be analyzed, which is significant, could possibly be reduced.

7.4 Special considerations

There are occasions when a perfectly sound transformer can produce reduced and full-current waves that differ in some way. These differences can normally be traced to the affects of the transformer core.

7.4.1 Core saturation

Core saturation is sometimes a problem when testing 2400 and 4800 V transformers and nearly always a problem when testing a series multiple transformer that includes either of these voltages. The best way to prevent these problems is to magnetically reverse bias the core prior to applying impulse voltage. Some experimentation will be necessary in order to determine the optimum remnant condition of the core. A positive dc voltage source of 100 V, current limited to 10 amps, when applied to the terminal to be impulsed will normally be adequate to force reverse saturation. So that the overall test time is not extended by this procedure, a high-voltage switching arrangement could be devised. The reverse biasing operation could proceed while the impulse generator was charging, between shots. Additional information about core saturation and biasing can be found in the Annex at the end of this guide.

7.4.2 Five-leg, three-phase cores

In three-phase core designs other than triplex, the core loops are shared by two or three phases. This sharing may cause small differences between the reduced and full-detection waves.

8. Verification of detector sensitivity

IEEE Std C57.12.90-1993, subclause 10.4, specifies that the sensitivity of the failure detection system be checked by placing a loop of wire around the core as a staged fault. This method can be proven to be adequate, but it may be impractical to have identical core and coil assemblies available on which to provide a verification check. There are considerable differences in the current wave shapes produced by transformers of differing size, form, BIL, and winding connection. Several transformers would have to be built with switchable staged faults and tested on a routine basis to certify the sensitivity of the fault detection system. A more practical method may be to connect a properly sized resistor across the secondary terminals to simulate a fault. Figure 38 compares a no-fault curve to a curve obtained with a staged single-turn fault. Figure 39 shows the same transformer but the no-fault curve is compared to a staged fault made by placing a 125 ohm resistor across the X1 and X3 terminals. The wave shapes are different, but if the simulated fault is detected then the single-turn fault would be detected also.

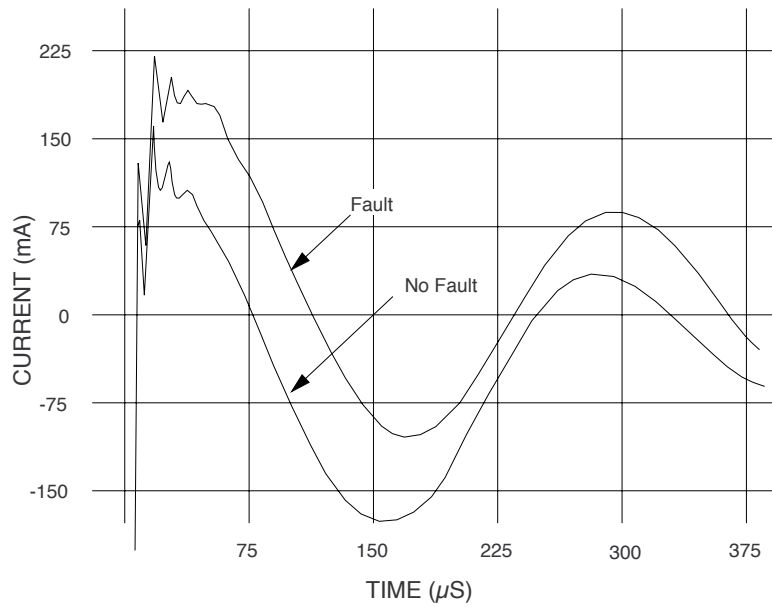

1 BUSH 50% LI Full
Max: -831mA Min: 231.1mA Overflow

Figure 38—Comparison, actual one-turn fault

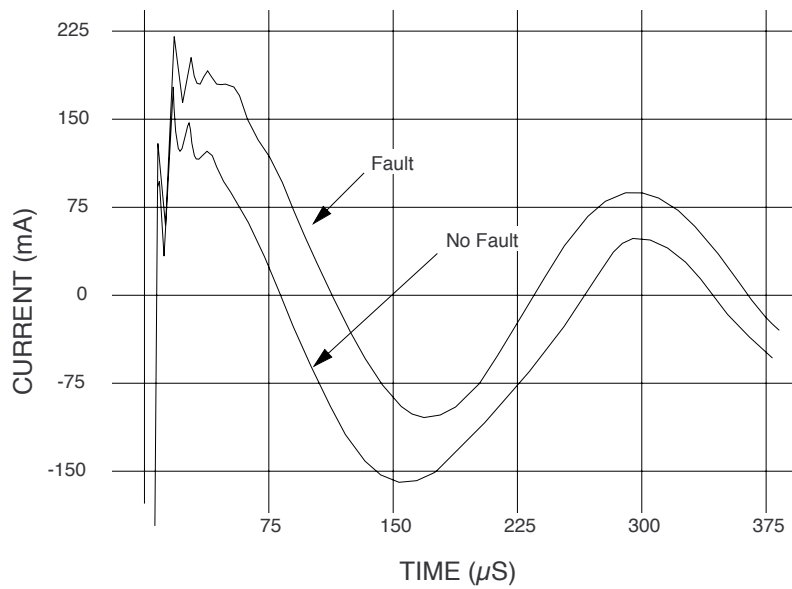

1 BUSH 50% LI Full
Max: -831mA Min: 231.1mA Overflow

Figure 39—Comparison, staged one-turn fault

A small, very high-voltage transformer is the most difficult in which to detect a one-turn fault. The location of the turn in the coil is also of some importance. Testing has been done which indicates that a single-turn fault can be detected even when testing a worst-case transformer. It is not known if a single-turn fault can be found in any transformer, regardless of its location.

It may not be necessary to demonstrate that all faults can be found, only that all faults not found by other tests can be detected. All transformers that are routinely impulse tested are also induced tested. The minimum induced test is twice the rated voltage; therefore, each turn in the transformer winding is stressed a minimum of twice the design voltage. If during an impulse test a turn in the winding is stressed less than that equivalent voltage, it is less important to detect a fault because it would be detected during induced testing.

If the impedance of the shorted turn is known as well as the voltage induction, the current flowing in the shorted turn can be determined. If the number of turns in the winding being tested is known, the change in test current due to the shorted turn can be calculated. The impedance of a shorted turn is made up of resistance and self-inductance. Self-inductance is small compared to the resistance of the turn, especially for small transformers. An estimate of the impedance of a shorted turn can be made by dividing the power frequency impedance of the winding being tested by the turns in the winding. In most cases the impedance will be less than the estimate and the effect on the test current more. The effect of the shorted turn is approximated by a current flowing in the low-voltage winding equal to the current in the hypothetical shorted turn divided by the number of low-voltage turns. The voltage induced across the low-voltage bushings during lightning impulse testing approximately equals the turns ratio voltage. If the secondary impedance is assumed to be small compared to the current limiting resistance, a minimum resistance value to place across the secondary winding when checking detector sensitivity can be calculated.

For larger distribution transformers, the inductance is a significant component of the impedance of a shorted turn. This is seldom a concern, because it is also much easier to detect a fault in higher kVA transformers. It should be possible to quadruple the value of resistance calculated by the resistance method and still trip the fault detector. However, the inductance effect can be approximated by calculating the leakage inductance of a hypothetical loop of wire surrounding the coil under test. This leakage inductance is found by subtracting the inductance of the coil under test from the inductance of the loop. Each inductance is calculated in free air, and the number of turns of the tested coil must be set to one in its inductance formula before the subtraction. The leakage inductance so found and the resistance of the loop of wire are then referred to the side under test.

Annex A

(informative)

Distribution transformer voltage distribution and impulse fault detection

A.1 Introduction

Routine impulse testing of distribution transformers as specified in IEEE Std C57.12.90-1993, subclause 10.4 requires that the test equipment demonstrate the ability to detect a single-turn fault. A typical fault can be simulated by placing a shorted turn of wire around the core leg and over the coil of a core and coil assembly.

IEEE Std C57.12.90-1993, subclause 10.4.2 lists two methods of fault detection, a ground-current method and a neutral-impedance method. While both methods make use of a current shunt, the voltage across which is examined to detect abnormalities within the coil being tested, the relative values of the R-C components of the shunt are quite different for the two methods. The following paragraphs are meant to provide a simplified discussion of impulse current shunts, the neutral impedance, and the response of typical distribution transformer coils to the application of impulse voltage. Illustrations of typical neutral-impedance shunt records that can result for particular transformer impulse failures are also included.

A.2 Components of an impulse current shunt

The detection of turn-to-turn breakdowns during impulse testing can be more difficult on small transformers of lower kVA, due to the increased number of electrical turns required by their designs. For example, a typical 5 kVA single-phase transformer may be designed for operation at 4 V per turn, while a 10 MVA three-phase transformer may be designed for operation at 40 V per turn. The smaller kVA transformer requires ten times the number of turns for a given operating voltage.

The large number of turns typical of distribution transformer designs produce response characteristics such that, during impulse tests, the capacitive and inductive components of impulse current differ in magnitude considerably. Typical values of the capacitive component could be in the range of 10 to 100 amps, while the inductive component may not exceed more than a few milliamps. Providing good fault detection sensitivity in the presence of such differing components of impulse current can be difficult. If a purely resistive current shunt (that is, a shunt that employed a “non-inductive” resistor) were to be used to provide a means of fault detection, then for any given ohmic value of that resistance, the magnitude of the voltage developed by the above mentioned capacitive component of current would be several orders of magnitude greater than that developed by the inductive component.

Selecting a particular value of resistance so that the signal magnitude produces the required vertical deflection on an oscilloscope presents a dilemma. If the resistance value was chosen based on the capacitive component of current, then the inductive component would produce a negligible deflection on the oscilloscope and the ability to detect changes in that component would be compromised. Conversely, if the resistance value was chosen based on the inductive component providing an adequate oscilloscope deflection, then the signal magnitude produced by the capacitive component would exceed full-scale deflection of the oscilloscope.

An acceptable method of addressing this dilemma is to connect a capacitor in parallel with the shunt resistor (refer to IEEE Std C57.98-1993, subclause 3.5, “Failure Detection”). It is the relative values of resistance and capacitance used in the shunt that qualify it as either a ground-current or neutral-impedance type of

shunt. Low values of resistance and capacitance characterize the ground-current shunt with a lower time constant and higher bandwidth than the high-value components used in the neutral-impedance shunt. The type of shunt to be used depends upon which components of current are considered most important for fault detection (refer to IEEE Std C57.98-1993, subclause 2.9, “Ground Current Traces”).

A.3 Fault detection in distribution and power transformers

An important difference between the test circuit setup used during impulse testing of power and distribution class transformers is brought about by the need to limit the voltage induced in non-impulsed windings to no more than eighty percent of the winding BIL. The high turn ratio of distribution transformers and the accompanying high ratio of BIL to rated 60 Hz voltage of the low-voltage winding enables their low-voltage windings to be left open circuit during test. In contrast, power class transformers often need to limit induced voltages by loading or short-circuiting the non-impulsed windings. Consequently, the sensitivity of the inductive component of current to the additional loading effect of a fault, such as a single shorted turn, is diminished.

Ground-current shunts are therefore used to monitor impulse currents when it is considered important to monitor all the components of the current, as in power transformer testing. The value of capacitance used in this shunt should be no larger than required to produce a reasonable magnitude of both the capacitive and inductive components of current. Providing that the components and connections are of good quality and low inductance, this shunt would produce a signal that closely resembles the actual wave shape of the impulse current.

Neutral-impedance shunts are used to monitor impulse currents when the inductive component of current is considered to be the more sensitive indicator of faults, as is typically the case in distribution transformers. The capacitance value used in this shunt is selected so that a reasonable signal magnitude is produced by accumulation of the charge provided by the inductive current. A resistor of high ohmic value is connected in parallel with the shunt capacitor to limit the time duration of the shunt signal. In this circuit the series capacitance of the winding under test and the shunt capacitor form an imperfect voltage divider. The voltage wave shape produced by this shunt may therefore resemble the wave shape of the applied voltage.

A.4 Equivalent network for a single-section, layer-wound transformer coil

Figure A.1 shows a capacitive network for a typical transformer coil containing a single-section, layer-wound, high-voltage winding. Layer-to-layer capacitances are relatively high because of the large adjacent surfaces and relatively thin interlayer insulation. Capacitance from either the outermost or innermost layers to the low-voltage winding is quite low because of the relatively thick major insulation. The capacitance from end turns to ground, as shown typically by the broken lines, is negligible because of the small exposed area of the layer end turns and their large separation from ground.

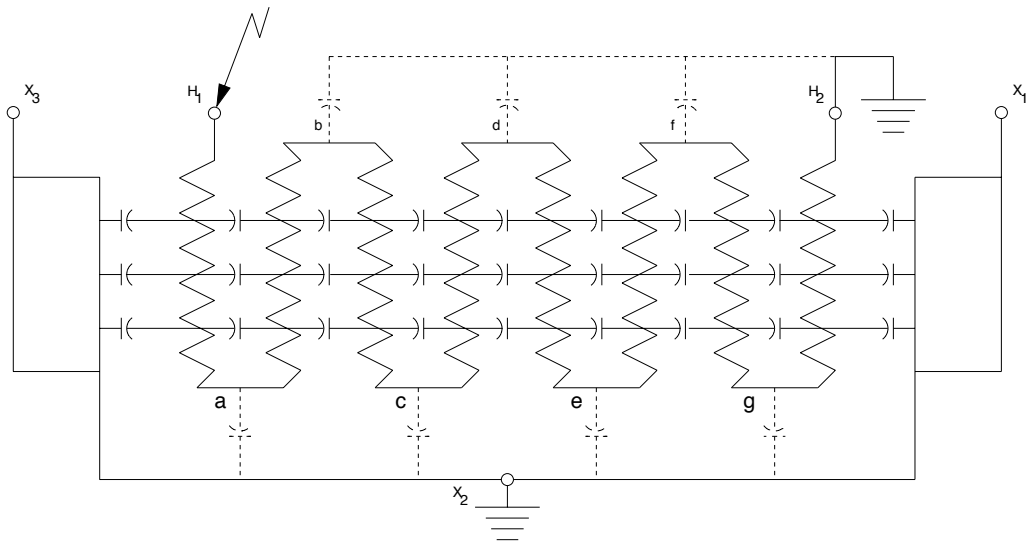

Figure A.1—Equivalent capacitance network for single-section layer winding

A.4.1 Impulse distribution for a single-section, layer-wound coil

Winding layer impedance includes the winding conductor resistance in series with a relatively large self-inductance. The inductance of the layers might be expected to limit the rate of rise of voltage within the windings and cause voltage oscillations typical of an L-C series circuit. For relatively slow impulse voltages (risetime > 1.2 microseconds) applied to distribution transformers, this is not generally the case. During the rising front of the applied voltage wave, the interlayer capacitances acquire charge and the points “b”, “d” and “f” increase in voltage relative to H₂ or ground. Figure A.2 shows the first three layers of the winding of Figure A.1 and the charging current paths for the interlayer capacitances of those layers. The distributed capacitance between H₁ and “b” is charged by a current. The current direction is through the winding from H₁ to “a”. As point “b” increases in voltage, the distributed capacitance between “a” and “c” is charged by a current with the current direction through the winding from “b” to “a”. Since these two currents are in opposition through the winding, they create opposing magnetic fields that result in a partial cancellation of the inductance of the two layers.

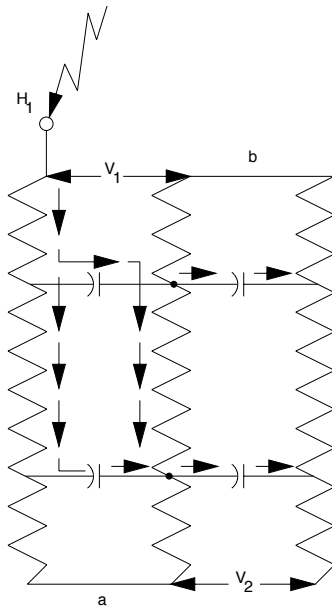

Figure A.2—Current flow due to impulse voltage

Similarly, the currents that charge the distributed capacitances between the remaining layers “b-d”, “c-e”, ... to “f-H₂” or ground, cause partial cancellation of the inductance of those layers. The overall effect of this process is to produce a more uniform, capacitive voltage distribution between the layers of the coil.

A.4.2 Layer voltage to ground

Figure A.3 represents typical layer voltage to ground during the first 5 microseconds for a distribution transformer coil of the type indicated in Figure A.1. As can be seen from that figure, the voltage is uniformly distributed throughout the winding, with no major oscillations and no appreciable evidence of a traveling wave. If the time to crest of the applied voltage were reduced to 1.2 microseconds or less, then minor oscillations may tend to occur that may increase layer-to-layer stress between H₁ and “b” and “a” and “c”. This would be due to the higher frequency content of the faster risetime impulse, the fact that the inductance in the H₁ layer was not completely cancelled, and the stray capacitance to ground.

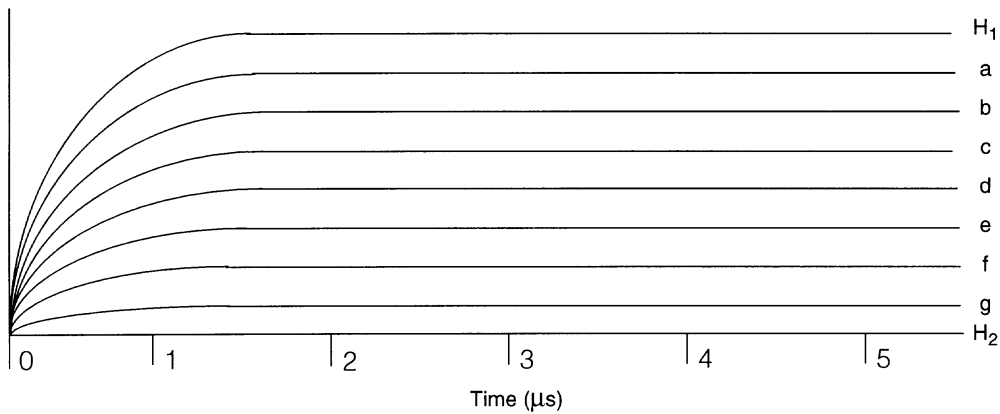

Figure A.3—Impulse voltage distribution of a single-section layer-wound coil

A.5 The effects of multiple winding sections

Figure A.4 shows a transformer that contains two high-voltage sections. This could be a 7.2×14.4 kV unit connected for 14.4 kV. Also shown are the capacitances that are most influential in shaping the current wave and in determining the initial voltage division within the winding. Figure A.5 depicts the winding schematically and indicates certain current directions that will be referenced in the text. Figure A.6 illustrates a typical impulse current wave shape, and Figure A.7 illustrates typical voltage distribution within this type of winding.

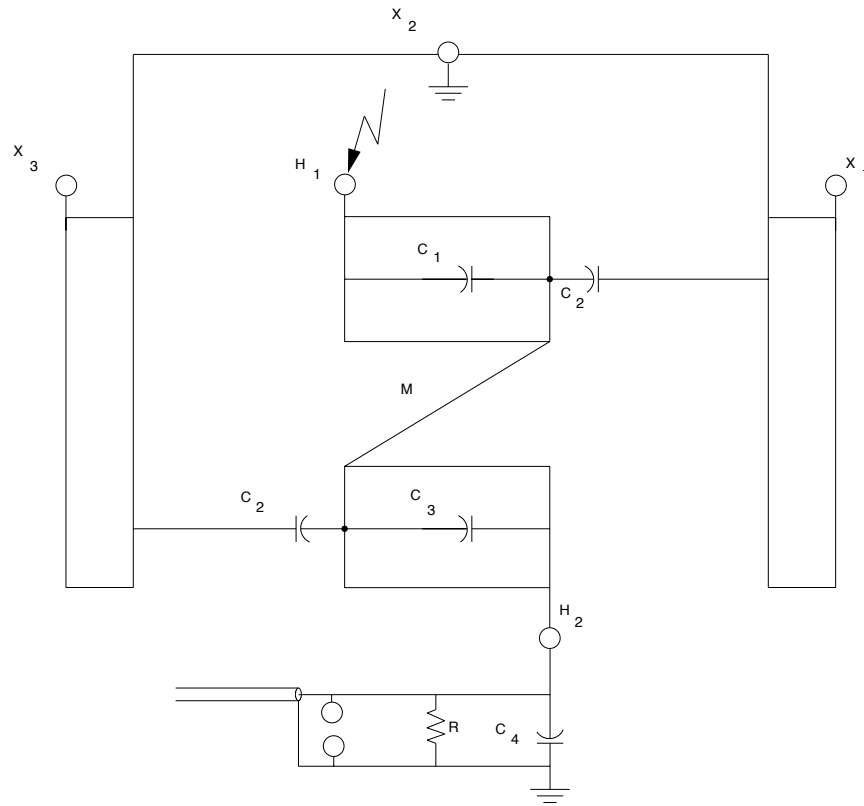

Figure A.4—Equivalent capacitance network for a two-section layer winding

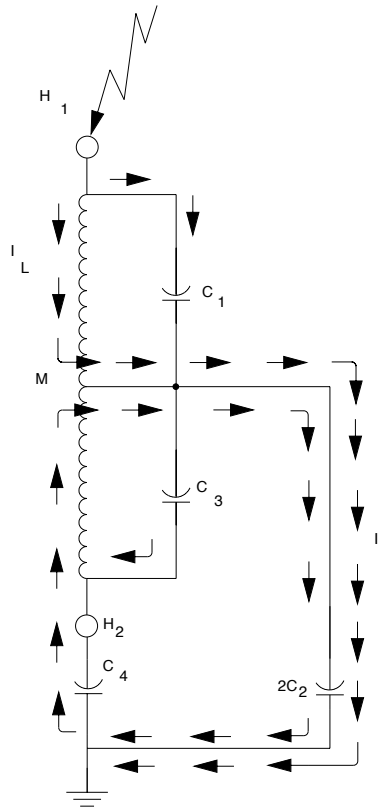

Figure A.5—Impulse current flow for a two-section layer winding

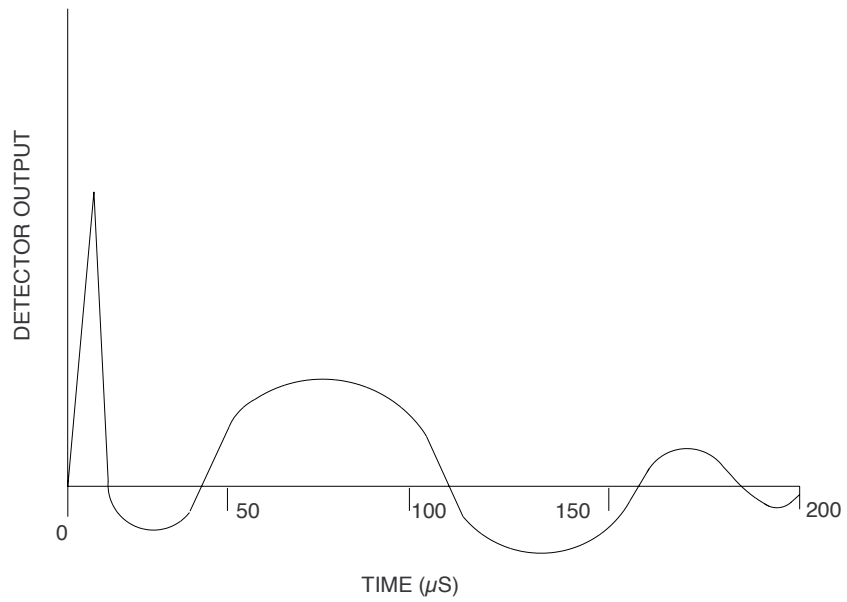

Figure A.6—R-C neutral current detector output for a two-section winding

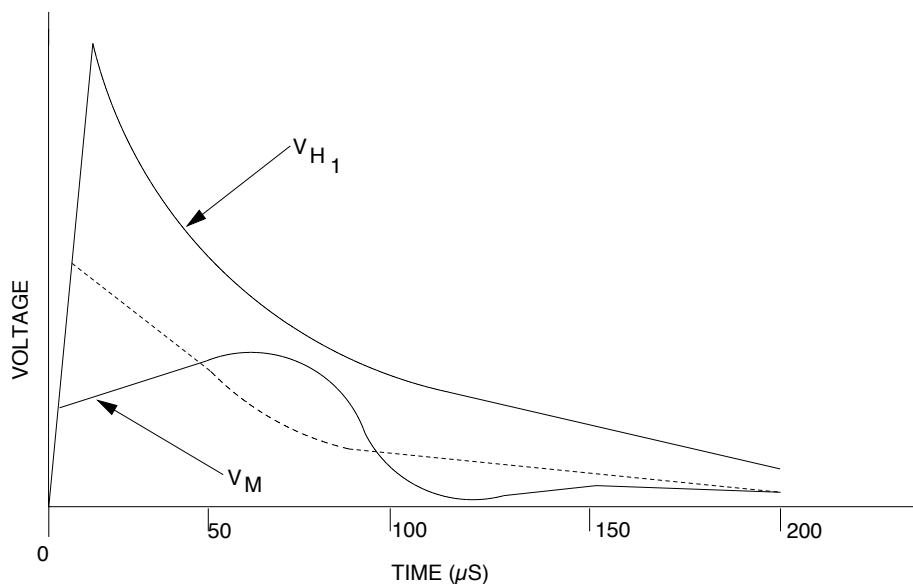

Figure A.7—Voltage distribution within a two-section winding

Capacitance C_1 and C_3 represent the series capacitance through the two winding sections. C_2 is the capacitance between each winding section and ground, C_4 is the capacitance of the neutral-impedance shunt, and M is the midpoint of the two winding sections. Note that recording instrument constraints will generally require that C_4 be significantly greater than C_1 , C_2 , or C_3 ; therefore, C_4 will have negligible effect on the internal voltage distribution.

The ratio of inductance to resistance for power transformer windings is high and their time constant long compared to the risetime of the impulse voltage. The initial current through the windings is therefore capacitive and has no inductive component. Thus, the initial voltage distribution will be determined by the interwinding capacitances. If the capacitance of C_1 was equal to the effective capacitance of the network formed by C_2 , C_3 and C_4 , then simple voltage division would cause the initial impulse voltage at M to be 50% of the voltage applied to H_1 . Unless specific design provisions are made, this will not be the case. The presence of ground capacitance C_2 will generally cause the capacitance of the above-mentioned network to be greater than C_1 . This capacitance ratio, and the fact that the mutual coupling between the two winding sections is less than perfect, will cause the initial voltage to ground at M to be less than 50%. Figure A.7 illustrates the wave shape of the voltage applied to V_{H1} and the midpoint voltage V_M . The dashed line indicates the 50% voltage wave shape that would result if the voltage distribution were ideal.

Since the initial voltage at V_M is less than 50% of that applied, it follows that the initial voltage across the upper winding section H_1 to M , will be greater than that across the lower section, M to ground. The initial voltage per turn of upper section would therefore be greater than the initial voltage per turn of lower section.

As inductive current becomes established, the greater voltage across the upper section would tend to cause a larger inductive component of current to flow in that section than would the voltage across the lower section. The return path for the difference in these two currents is through the ground capacitance C_2 , as indicated by I_L of Figure A.5. The product of initial current and turns (amp*turns) would therefore tend to be higher for the upper winding section than for the lower section. However, since both sections are mutually coupled, the greater magnetic flux excited by the amp*turns of the upper section mutually couple with the turns of the lower section, inducing a voltage that would tend to increase the voltage of that section. Consequently, as the rate of change of current I_L and therefore flux increases the voltage induced in the lower winding section, it tends to force equalization in the volts per turn. An additional consequence is that, as the voltage at M

increases, an induced current is sourced by the lower section, through C_3 and C_2 , thereby transferring energy to those capacitances. The circulating current through C_2 returns to the lower winding section through C_4 , in a direction opposite that of the initial impulse current. Circulating current is indicated by arrows on Figure A.5.

The effect of this process can be seen in both Figures A.6 and A.7. In Figure A.6 the initial direction of the impulse current changes rather abruptly after about 15 microseconds. This is the effect of the current reversal through C_4 , brought about by the return of the induced current being sourced by the lower winding section. In Figure A.7 the magnitude of V_M continues to increase even though the applied voltage V_{H1} is decreasing.

From an initial value of less than 50%, the midpoint voltage V_M is caused to increase by the increasing rate of change of flux, as is the circulating current until, at about 40 microseconds (in the case of this particular example), the magnitude of V_M becomes equal to the 50% (dashed), ideal voltage value. At this point the voltage difference across both sections, and therefore the volts per turn, are equal. Also, the current magnitudes in both sections become equal. That is, the current flowing from H_1 to M becomes equal in magnitude to that flowing from H_2 to M. The amp*turns are therefore equal, as both sections share the current through C_2 . This is also the point of maximum rate of change of induced voltage and therefore corresponds to a minimum rate of change of flux, that is, a maximum or peak excursion of the flux.

The continued decay of the impulse voltage on V_{H1} does not immediately produce a corresponding reduction in V_M , due to the long time constant of the windings. Consequently, the decay of the applied impulse voltage only leads to a reduction in the voltage across the upper section, with a corresponding decrease in the volts per turn. Meanwhile, the flux direction reverses and the resulting increase in its rate of change continues to increase the voltage at M. The maximum rate of change of flux corresponds to the maximum value of V_M .

As the flux approaches its next maximum, the magnitude of V_M starts to decrease and energy is removed from the capacitances, as voltage is now induced into the upper section to balance the volts per turn. This energy exchange cycle repeats, causing the midpoint voltage to oscillate about the axis of the dashed voltage wave shape. The oscillatory voltage induced at M results in an oscillatory current through the ground capacitance C_2 that returns through the neutral-impedance capacitor C_4 , as indicated by the circulating arrows of Figure A.5.

Depending on the relative values of capacitance and inductance, the first reversal of current may or may not extend below the zero axis. Figure A.6 illustrates a typical impulse current wave shape, including the current reversals or oscillations referred to above.

A transformer containing three high-voltage sections is shown in Figure A.8, where A and B are the interconnecting points of the sections. This could be a 2.4×7.2 kV unit connected for 7.2 kV. The equivalent circuit diagram is indicated by Figure A.9, and a typical impulse current wave shape is illustrated in Figure A.10. Typical voltage distribution within the winding is illustrated by Figure A.11, where the dashed lines represent the 66.7% and 33.3% ideal voltage values that would result if distribution were perfect.

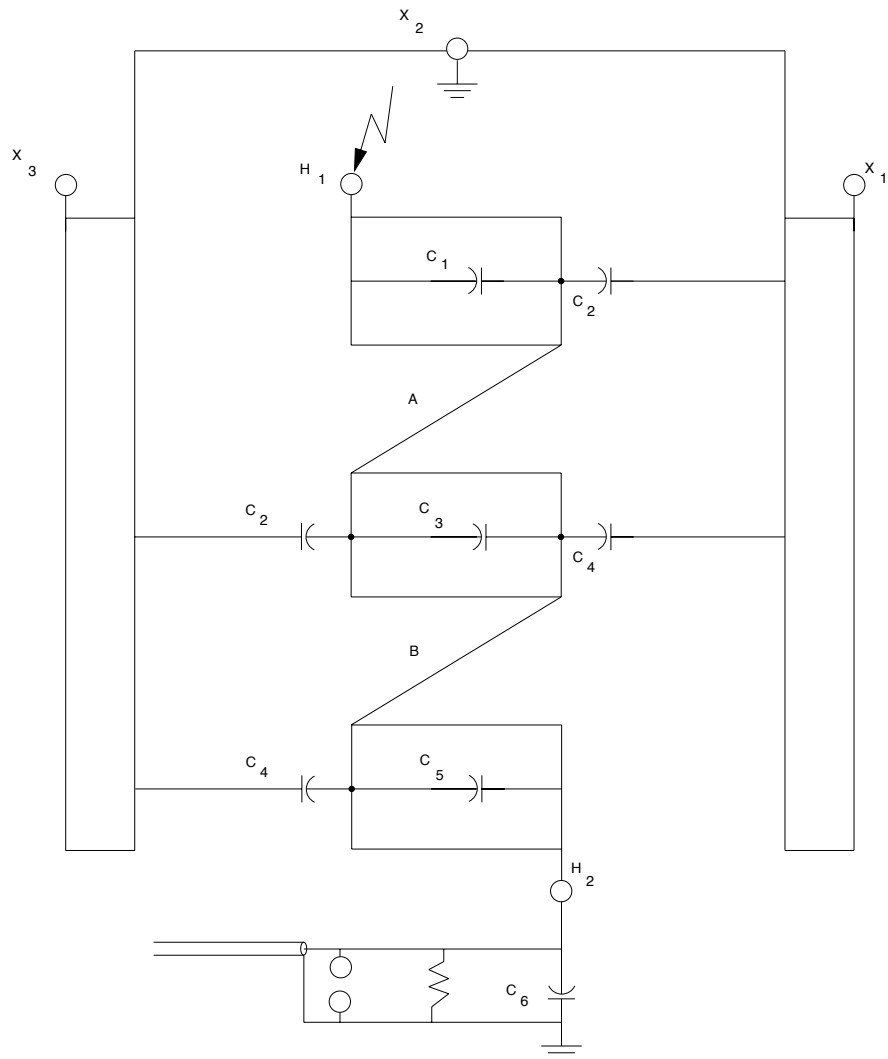

Figure A.8—Three-section layer winding with equivalent capacitances shown

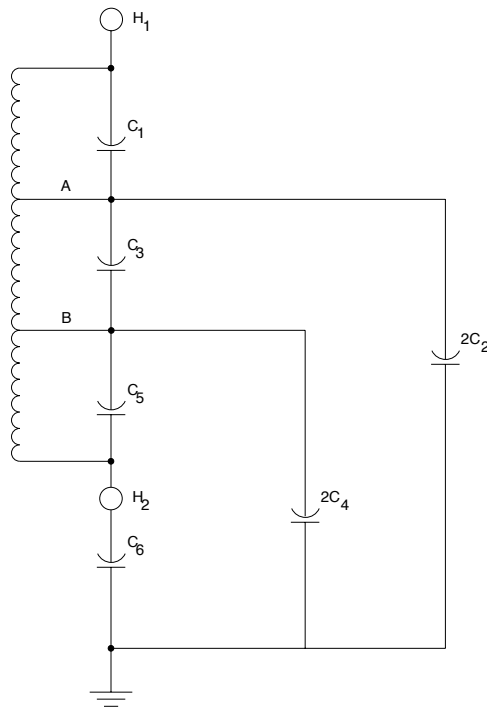

Figure A.9—Equivalent capacitance network for a three-section layer winding

As in the case of the two-section winding, unless special design provisions are made, the capacitance to ground, indicated as C_2 and C_4 in Figure A.9, and the imperfect coupling between the winding sections would cause the initial voltage distribution to be non-uniform. The initial voltage H_1 to A would therefore be greater than the voltage A to B, and voltage A to B would be greater than B to ground or B to H_2 . (In this example the neutral impedance capacitor is C_6 ; therefore, the voltage H_2 to ground would be negligible.)

Voltage distribution would progress in a similar manner to that of the two-section transformer. The greater volts per turn impressed across the upper winding section would initiate a flux that would couple with the lower sections, tending to equalize the volts per turn and thereby increasing the voltage V_A and V_B . As inductive current and therefore flux became established, the component of current through point A into C_2 would increment more readily (be of a higher frequency) than would that through point B into C_4 , due to the fewer turns (lower inductance) in series with point A. Thus, an induced voltage produced by the flux would cause the voltage V_A to approach its ideal value before V_B . This effect is illustrated in Figure A.11 by the relative increase in the magnitudes of V_A and V_B . From an initial value less than the 66.7% voltage value, V_A increases until, at about 20 microseconds (in this particular example), its magnitude equals the 66.7% voltage value. During the same time period, V_B can be seen to be relatively constant.

As the impulse current and therefore the flux achieves its first maximum and changes direction, V_A and V_B continue to increase and transfer energy into C_2 and C_4 . The energy exchange between the capacitance and inductance of the windings continues in a similar manner to that of the two-section winding discussed above, except that the additional section produces an additional sequence of energy exchanges. The inductance of the upper section and the capacitance C_2 result in one natural frequency while the greater inductance of the upper plus middle sections and capacitance C_4 produce a second, slightly lower frequency. The voltage at A therefore achieves a maximum slightly ahead of that at B.

A typical impulse current wave shape for such a winding, as illustrated by Figure A.10, contains more pronounced oscillations. After an initial positive excursion the impulse current changes direction as the sum of the induced currents, sourced by both the middle and lower winding sections, returns via C_6 .

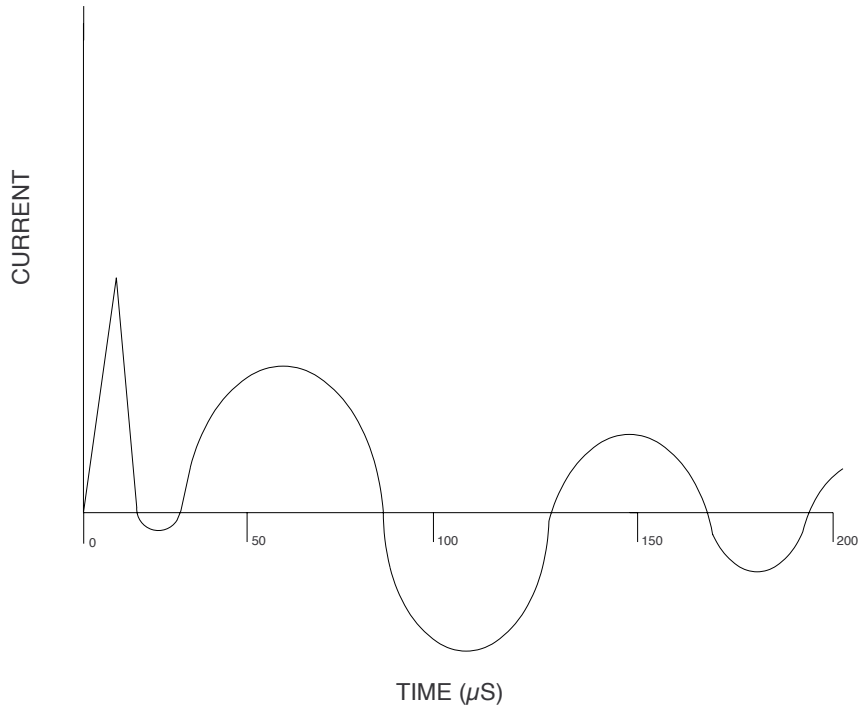

Figure A.10—Impulse current wave for a three-section layer winding

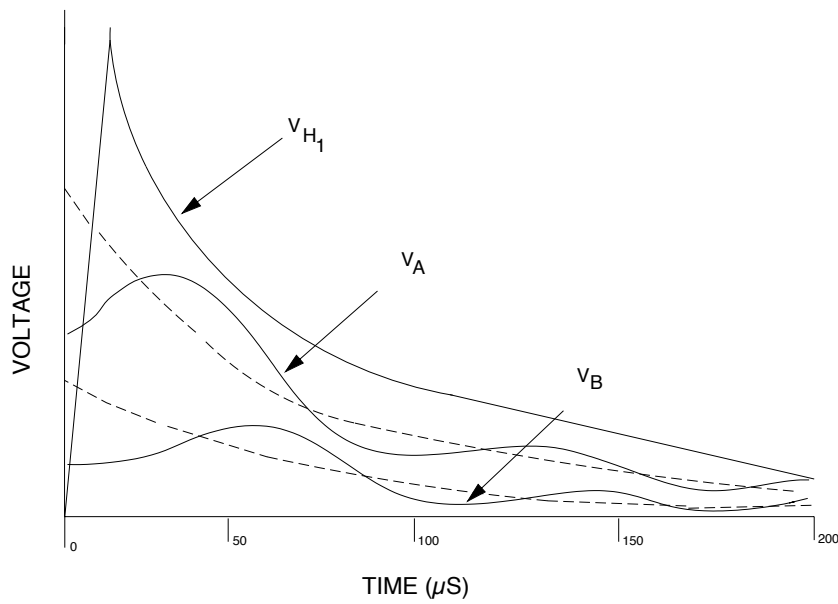

Figure A.11—Impulse voltage distribution within a three-section layer winding

Transformer windings employing more than three sections would have correspondingly lower inductance per section and more series and shunt capacitive elements. Each additional section would produce an impulse response, the natural frequency of which would depend on its location in the winding. The higher frequencies are produced at those sections with the lowest series inductance, which are sections closest to the applied voltage end. The maximum voltage to ground would therefore occur earlier, at the applied voltage end of the winding and apparently propagate into the winding, producing what's commonly referred to as a traveling wave.

As more sections are included in a given winding design, the greater number of series capacitance elements tends to reduce the effective series capacitance of the winding. This has the effect of reducing the magnitude of the initial capacitive component of impulse current so that a large value of capacitance in the shunt becomes unnecessary. Such winding designs, for example disc windings, are employed in power transformers.

A.6 Turn-to-turn and layer-to-layer winding faults

Figures A.12 through A.17 indicate three typical fault conditions with corresponding impulse-current oscillograms. To simplify the diagrams, I_C has been omitted and C_1 has been included in Figure A.14 only. The effect of the relatively high value of C_2 and the resulting voltage divider effect are made obvious by the similarity of these current wave shapes to the applied voltage wave shapes.

Figures A.12 and A.13 illustrate the effect of a fault from point to point in the high-voltage winding such as from turn to turn, from layer to layer, or from tap to tap. I_L indicates the fault current path from H_1 to H_2 , bypassing part of the winding. The additional circulating arrows indicate the path of a circulating current, induced in the shorted winding section by autotransformer action, coupling the shorted turns to the nonshorted turns of the winding under test. The effect of this type of fault is twofold. The total turn count is reduced by the number of turns included in the shorted section, and the circulating current reduces the impedance of the remaining nonshorted turns. Any reduction in winding impedance causes an increase in the current I_L that increases the charge accumulated by shunt capacitor C_2 . The resulting current oscillogram therefore indicates a departure from the expected wave shape, increasing in magnitude from a point in time shortly after the fault occurs. The more turns involved in the fault, the greater the change in I_L and the more dramatic the departure from the expected wave shape.

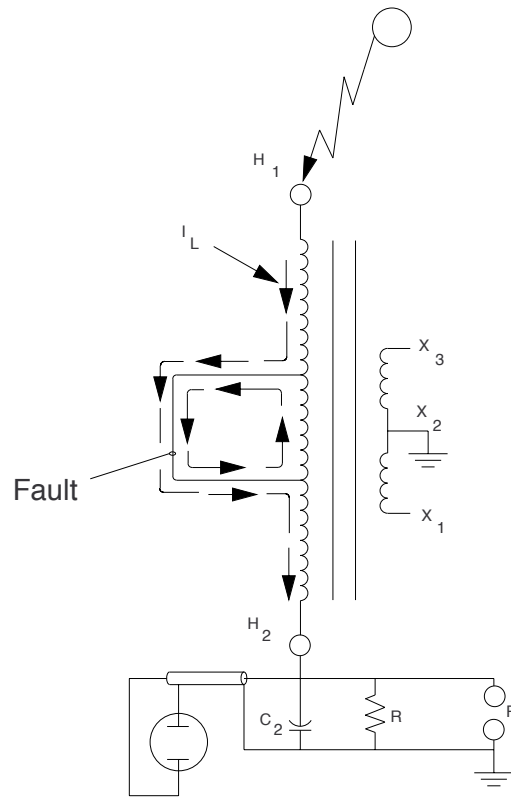

Figure A.12—Layer-wound coil with a fault within the winding

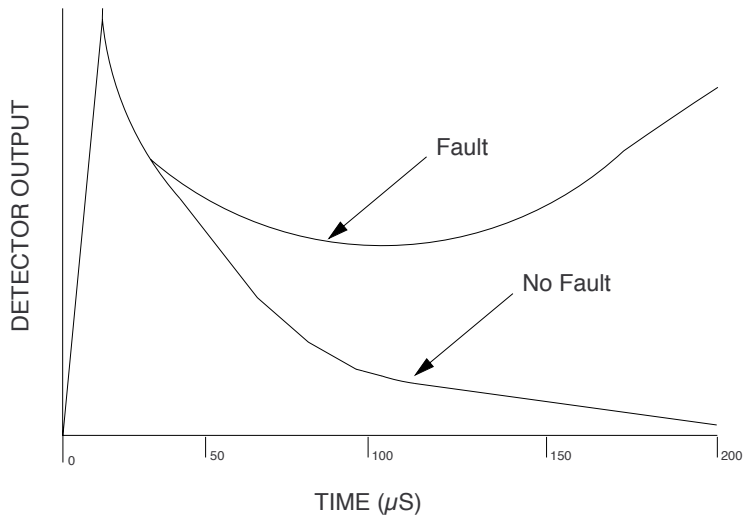

Figure A.13—R-C neutral detector output with and without a winding fault

Any turn-to-turn fault that occurs in any mutually coupled winding during an impulse voltage application tends to reduce the impedance of the winding under test, thereby causing an increase in I_L . The ability to detect such a change is at an optimum when the unfaulted magnitude of I_L is at a minimum, that is, when any mutually coupled windings are unloaded or open circuited.

A.7 High-voltage winding to ground faults

Figures A.14 and A.15 illustrate the effect of a fault to ground from the applied voltage end of the high-voltage winding, for example from the high-voltage lead that connects the winding to H_1 . It's important to note that in this case there are no winding turns in the fault path. The accompanying oscillogram indicates the effect that such a fault would produce on the impulse current. The failure diverts current around the winding and shunt, causing the impulse current wave shape to rapidly collapse and oscillate about zero.

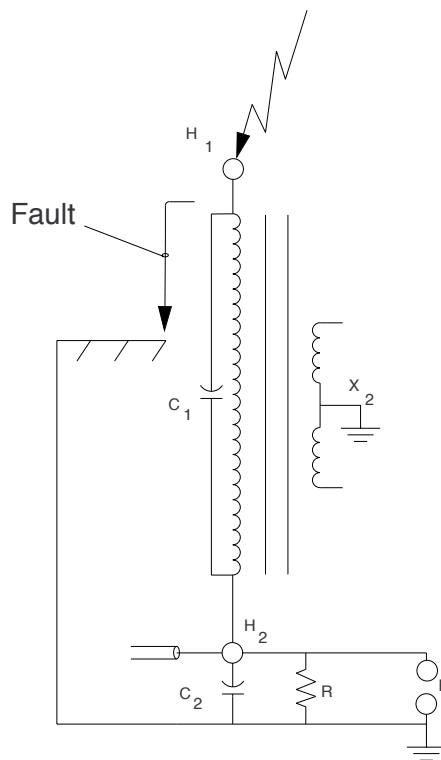

Figure A.14—Fault from bushing to ground

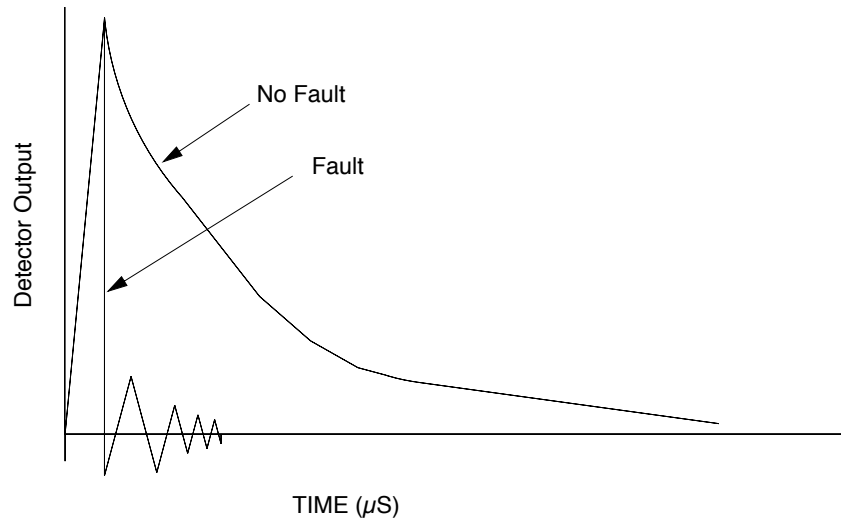

Figure A.15—R-C neutral detector output with a fault from bushing to ground

Figures A.16 and A.17 illustrate the effect of a fault to ground from an internal section of the high-voltage winding, such as a tap changer lead. The fault current path from H_1 to ground is indicated by I_L . As in the case of the turn-to-turn fault discussed above, autotransformer action causes an induced current to flow through the fault, the section of winding bypassed by the fault, and in this case, the shunt. This induced circulating current flows through the fault path in the same direction as I_L , but flows through the shunt in a direction opposite to the direction I_L had before the fault. The accompanying oscillogram indicates the effect of this fault on the impulse current wave shape. Prior to the fault, the current increases as would be expected. The occurrence of the fault causes the current through the shunt to change direction. At this point the behavior of the current wave shape would depend on how much of the winding was being bypassed by the fault. If the fault was close to the H2 terminal, the induced circulating current would be small and the current wave shape would tend slowly toward zero. For fault conditions closer to the center of the winding the rate of collapse would increase, and the wave shape would overshoot zero and tend to oscillate, as indicated by Figure A.17 oscillogram. Faults that occurred closer to the H1 terminal would increase the rate at which the current wave shape collapsed, producing a current wave shape more like that in Figure A.15.

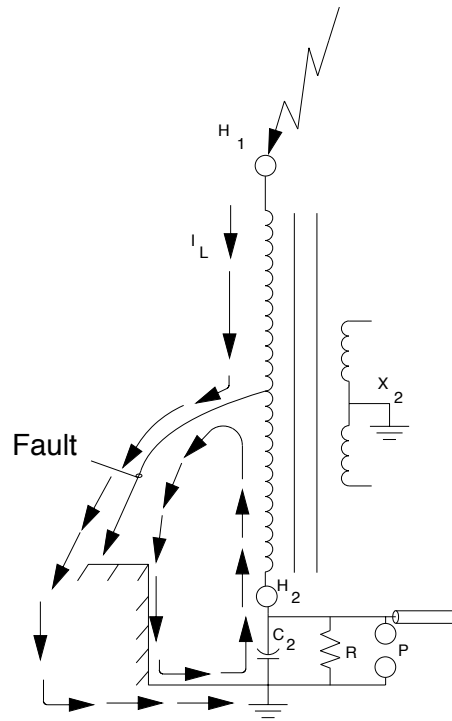

Figure A.16—Layer-wound coil with a fault from winding to ground

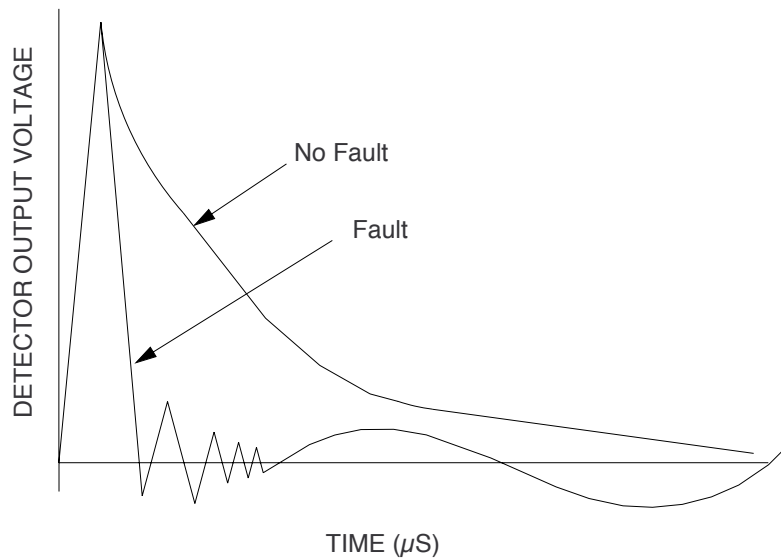

Figure A.17—R-C neutral shunt detector output with a fault to ground within the winding

Note that the behavior discussed in this section relates to faults to ground from the winding under test. Faults to ground from non-impulsed, ground-referenced windings would produce indications similar to turn-to-turn faults.

A.8 Effects of core saturation

The increased sensitivity to changes in I_L provided by the neutral-impedance shunt has the disadvantage that the shunt is also sensitive to the nonlinear characteristics of the core. This is compounded by the fact that the ratio of BIL to rated 60 Hz voltage increases as the rated voltage decreases. For example, a 95 kV test level is required for 7.2/12.24 kV rated windings, a ratio of 13.2 : 1, a 60 kV test level is required for windings rated 2.4/4.16 kV, a ratio of 25.0 to 1. In the case of dual-voltage transformer where the same BIL applies to both voltage ratings, the ratio of BIL to rated voltage can be as high as 39.6 : 1. Consequently, impulse tests on lower-voltage transformers can more readily drive their cores to magnetic saturation. At the higher BIL to rated voltage ratios, the effects of core saturation may be evident during the first voltage application.

The effect of impulse voltage on the core of a typical distribution transformer is illustrated in Figure A.18. In this case the design of the transformer and the relative magnitude of the impulse voltages are such that three voltage applications produce the partial hysteresis loops 1a, 2a, and 3a. The relatively constant slope of the initial portion of the magnetization curve has the effect that the first two voltage applications produce similar impulse currents I_L of very similar magnitude. However, the unipolar form of the impulses produce a unidirectional magnetization, as indicated by 1a and 2a, which results in an accumulation of remnant magnetic flux or a magnetic bias. Application of the third impulse extends core magnetization into the nonlinear portion of the curve, resulting in a disproportionate increase in I_L . Subsequent impulses of the same polarity would drive the core into saturation. Impulse current records obtained from a neutral-impedance shunt, corresponding to the three voltage applications, are indicated in Figure A.19. The similarity between these records and those of Figure A.13 should be noted.

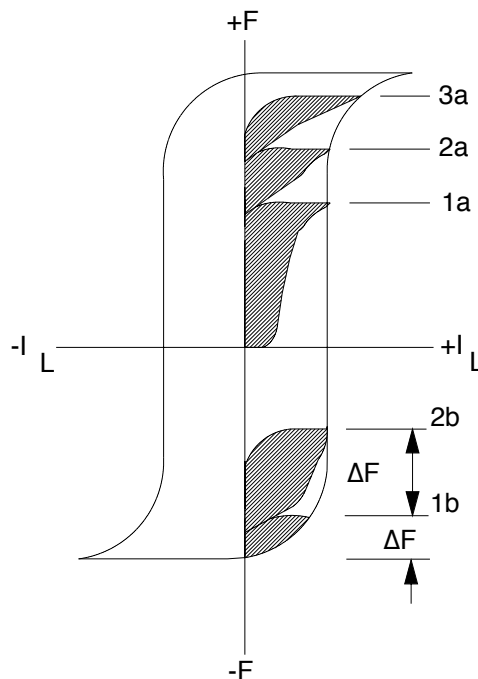

Figure A.18—Effects of core saturation due to application of multiple impulse voltage tests

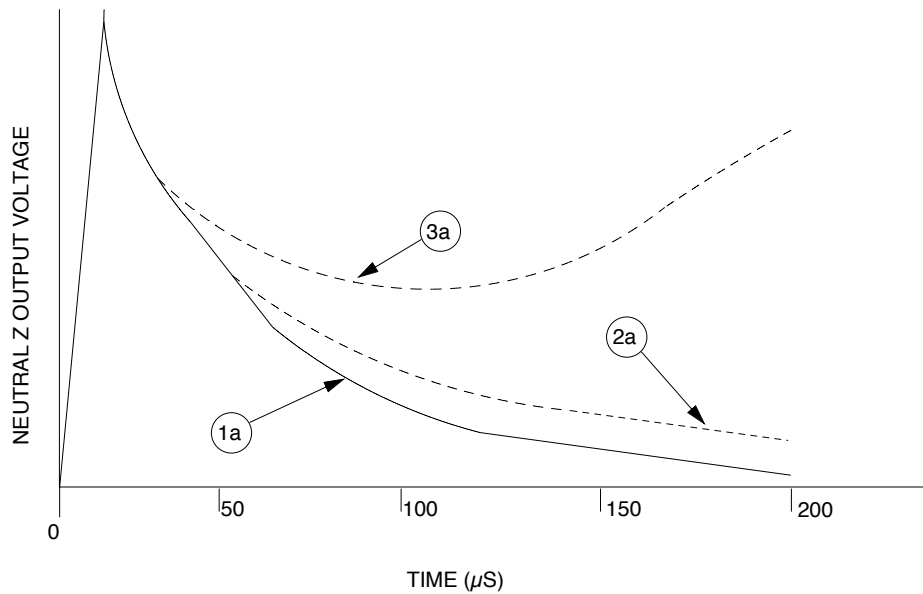

Figure A.19—R-C neutral shunt detector with and without core saturation

When core magnetization is suspected of causing misleading indications of impulse faults, the reversible and repeatable nature of magnetizing effects should be explored. It should be noted that the current wave shape for core saturation, shown by curve 3a in Figure A.19, resembles the single-turn fault shown by the curve in Figure A.13.

A.9 Eliminating core saturation

Magnetic polarization of a transformer core can be controlled by any one of three methods.

- a) It can be reduced by either reversing the polarity of the applied impulse, or reversing the H_1 and H_2 connections. In either case applying successive impulses will reverse the magnetization. If the winding under test is not fully insulated, then reversing the polarity of the applied impulse may be preferred.
- b) It can be reduced by applying rated 60 Hz voltage for a few seconds and then gradually decreasing the voltage to zero.
- c) It can be reduced by momentarily circulating dc current of reverse polarity through one of the transformer windings. For example, if saturation was caused by applying negative polarity impulses to H_1 , then the core can be saturated in the reverse direction by connecting the negative terminal of a dc source to X_2 , and then briefly establishing contact between the positive terminal of the dc source and X_1 .

Note that method (a) can be used to control the degree of magnetization incrementally, method (b) will leave the core in a demagnetized state, and method (c) will drive the core to a saturated state.

If the core has been saturated in reverse, and if the reduced and full-voltage impulses are then applied, partial hysteresis loops 1b and 2b of Figure A.18 will result and impulse current wave shapes as illustrated in Figure A.20 may be recorded. In this case, since the core is being driven away from saturation, it is the first pulse of the series that drives the core along the more nonlinear portion of the magnetization curve. The magnitude of I_L , even at the reduced voltage level, may then be greater than that recorded during the subsequent full

voltage application. This is simply the result of the slope of the magnetization curve in the area of saturation producing higher ratios of I_L to F . Subsequent voltage applications would yield consistent impulse current wave shapes, until the opposite polarity saturation point was approached.

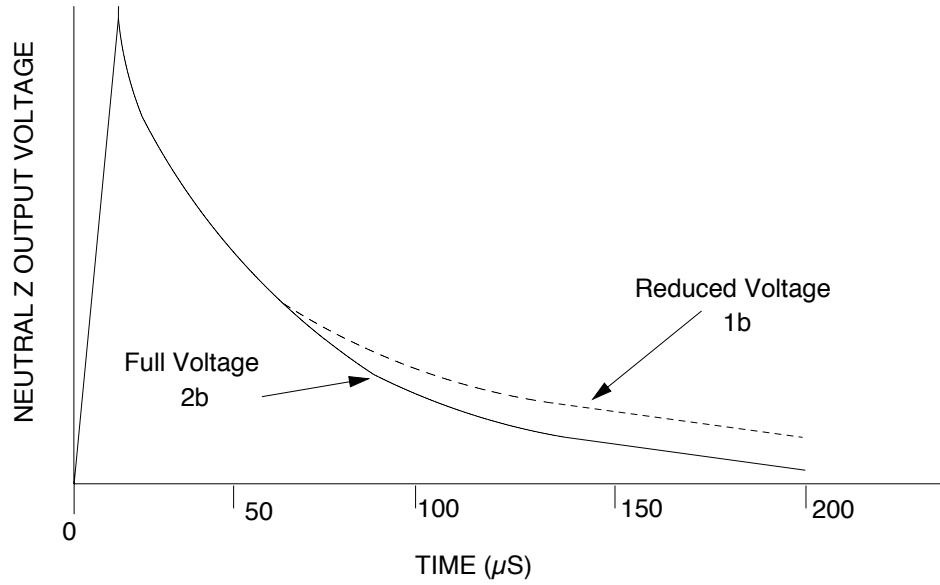

Figure A.20—R-C neutral-current detector output with core saturation and with the impulse voltage polarity reversed

(An unpublished thesis by Graham Johnson was the primary source for the impulse test theory included in Annex A.)